



# Ultra·Aire™ XT105H



PATENTS:  
D570,988  
8,069,681  
9,052,132

## Installation Instructions

**INSTALLATION BY A HVAC PROFESSIONAL IS RECOMMENDED**

The Ultra-Aire XT105H is a whole house ventilating dehumidifier that is integrated into the heating and cooling system to provide the ultimate in comfort, health and property protection through:

- Dehumidification
- Fresh Air Ventilation (Optional)
- Air Filtration

**HVAC Installer: Please Leave Manual for Homeowner**

P/N: 4032240 Serial No.: \_\_\_\_\_ Install Date: \_\_\_\_\_

Sold by: \_\_\_\_\_

# TABLE OF CONTENTS

<b>Safety Instructions</b> .....	<b>3</b>
<b>Specifications</b> .....	<b>4</b>
<b>Optional Accessories</b> .....	<b>5</b>
<b>Removal of Compressor Shipping Support</b> .....	<b>5</b>
<b>Dehumidifier Set Up</b> .....	<b>6</b>
<b>Attaching Duct Collars</b> .....	<b>7</b>
<b>Electrical Requirements</b> .....	<b>8</b>
<b>Drain Installation</b> .....	<b>9</b>
<b>Ducting to HVAC Systems</b> .....	<b>10</b>
Recommended HVAC System Installations .....	11
Alternative HVAC System Installations.....	12
Recommended Multiple HVAC Systems Installation .....	13
No Existing Ductwork Installation .....	14
<b>Fresh Air Ventilation</b> .....	<b>15</b>
Determine Ventilation Requirements .....	16
<b>Controls</b> .....	<b>17</b>
<b>Air Filtration</b> .....	<b>19</b>
MERV Rating Chart .....	20
<b>Service</b> .....	<b>21</b>
Troubleshooting.....	22
<b>Warranty</b> .....	<b>24</b>

Ultra-Aire is committed to manufacturing quality products. To maintain our standards, product specifications may change without notice.



4201 Lien Rd. Madison, WI 53704  
1-800-533-7533  
www.Thermastor.com | www.Ultra-Aire.com

© 2015 Therma-Stor LLC

# SAFETY INSTRUCTIONS

**READ THE INSTALLATION, OPERATION AND MAINTENANCE INSTRUCTIONS CAREFULLY BEFORE INSTALLING AND OPERATING THIS DEVICE. PROPER ADHERENCE TO THESE INSTRUCTIONS IS ESSENTIAL TO OBTAIN MAXIMUM BENEFIT FROM YOUR ULTRA-AIRE WHOLE HOUSE VENTILATING DEHUMIDIFIER.**

## **⚠ WARNING!**

**THIS SYMBOL MEANS IMPORTANT INSTRUCTIONS. FAILURE TO HEED THEM CAN RESULT IN SERIOUS INJURY OR DEATH.**

## **⚠ CAUTION!**

**THIS SYMBOL MEANS IMPORTANT INSTRUCTIONS. FAILURE TO HEED THEM CAN RESULT IN INJURY OR MATERIAL PROPERTY DAMAGE.**

### Registrations



The Ultra-Aire XT105H conforms to unified standard UL 60335-2-40 and CSA Standard C22.2 No. 92.

## **⚠ WARNING!**

**120 VOLTS MAY CAUSE SERIOUS INJURY FROM ELECTRIC SHOCK. DISCONNECT ELECTRICAL POWER BEFORE STARTING INSTALLATION OR SERVICING, AND LEAVE POWER DISCONNECTED UNTIL INSTALLATION OR SERVICE IS COMPLETED.**

## **⚠ CAUTION!**

**READ ALL INSTRUCTIONS BEFORE BEGINNING INSTALLATION.**

**ALWAYS USE CAUTION AND WEAR CUT RESISTANT GLOVES WHEN HANDLING SHEET METAL.**

**IMPROPER INSTALLATION MAY CAUSE PROPERTY DAMAGE OR INJURY. INSTALLATION, SERVICE, AND MAINTENANCE MUST BE PERFORMED BY A QUALIFIED SERVICE TECHNICIAN.**

**DEHUMIDIFIER IS HEAVY. HANDLE WITH CARE AND FOLLOW INSTALLATION INSTRUCTIONS.**

**DO NOT USE IN POOL APPLICATIONS, OR WARRANTY WILL BE VOID.**

**NEVER OPERATE A UNIT WITH A DAMAGED POWER CORD. IF THE POWER CORD IS DAMAGED, IT MUST BE REPLACED BY THE MANUFACTURER, ITS SERVICE AGENT, OR A SIMILARLY QUALIFIED PERSON IN ORDER TO AVOID A HAZARD.**

**THIS APPLIANCE IS NOT INTENDED FOR USE BY PERSONS (INCLUDING CHILDREN) WITH REDUCED PHYSICAL, SENSORY OR MENTAL CAPABILITIES, OR LACK OF EXPERIENCE OR KNOWLEDGE, UNLESS THEY HAVE BEEN GIVEN SUPERVISION OR INSTRUCTION CONCERNING THE USE OF THE APPLIANCE BY A PERSON RESPONSIBLE FOR THEIR SAFETY. CHILDREN SHOULD BE SUPERVISED TO ENSURE THAT THEY DO NOT PLAY WITH THE APPLIANCE.**

# SPECIFICATIONS

<b>Part Number:</b>	4032240		
<b>Blower:</b>	257 CFM @ 0.0" WG 206 CFM @ 0.2" WG 146 CFM @ 0.4" WG		
<b>Power:</b>	530 Watts @ 80°F and 60% RH		
<b>Supply Voltage:</b>	115 VAC – 1phase – 60 Hz		
<b>Current Draw:</b>	4.9 Amps		
<b>Circuit Requirement:</b>	15 Amp Dedicated		
<b>Energy Factor:</b>	4.2 L/kWh		
<b>Operating Range:</b>	56°F Min, 95°F Max (Inlet Air Temperature)		
<b>Sized for:</b>	Up to 2,500 Sq. Ft. - Typical		
<b>Minimum Performance at:</b>	<b>80°F and 60% RH</b>	<b>70°F and 60% RH</b>	
Water Removal:	105 pints/day	85 pints/day	
Efficiency:	8.8 Pints/kWh	8.0 Pints/kWh	
<b>Duct Connections:</b>	6" Round Inlet; 10" Round Inlet; 10" Oval Outlet		
<b>Air Filter:</b>	MERV-11, Standard Pleat		
Efficiency:	65% ASHRAE Dust Spot		
Size:	16" x 20" x 2"		
<b>Optional Air Filter:</b>	MERV-14, Embossed Pleat (will need filter housing)		
Efficiency:	95% ASHRAE Dust Spot		
Size:	20" x 24" x 4"		
<b>Power Cord:</b>	9', 115VAC, Ground		
<b>Internal Insulated Cabinet:</b>	Yes		
<b>Drain Connection:</b>	3/4" Threaded Female NPT		
<b>Refrigerant Type:</b>	R410A (Refer to manufacturers label for more information)		
Refrigerant Amount:	1 lb., 10 oz.		
<b>Dimensions:</b>	<b>Unit With Collars</b>	<b>Unit Without Collars</b>	<b>Shipping</b>
Width:	20 1/4"	20 1/4"	25"
Height:	21 3/4"	21 3/4"	28"
Length:	41 1/2"	37 3/4"	42"
Weight:	140 lbs.	139 lbs.	162 lbs.

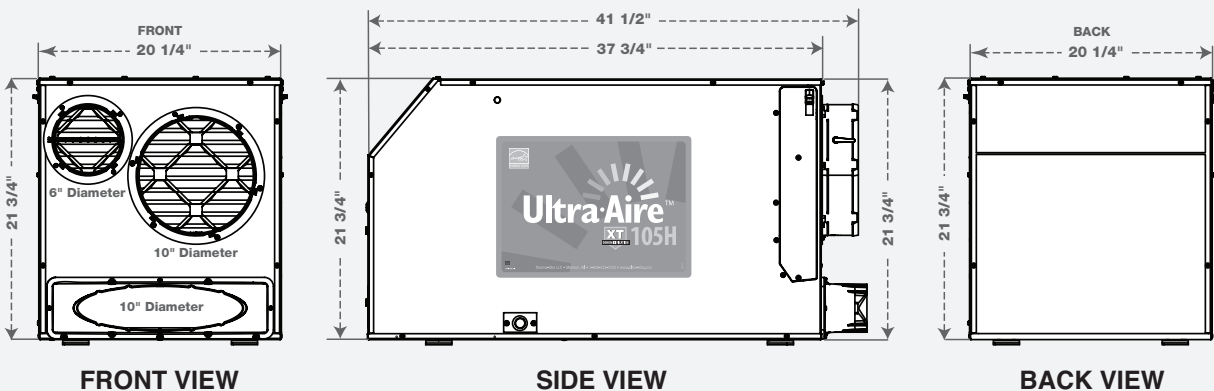

# OPTIONAL ACCESSORIES

4028539	DEH 3000 Control
4028407	DEH 3000R Control (with remote)
4021475	MERV 11 Filter (16"x20"x2")
4027420	MERV 11 Filters 4-Pack
4027424	MERV 11 Filters 12-Pack
4028614	Pump Kit
4036685	Hang Kit
4025287	MERV 14 Filter Housing
4024370	MERV 14 Filter (20"x24"x4")
4029087	MERV 14 Filters 3-Pack
4023672	6" Motorized Damper
4026859	6" Flex Duct 25'
4020128	6" Flex Insulated Duct 25'
4020656	6" Inlet Hood
4024375	10" Gravity Damper
4026969	10" Flex Duct 25'
4022126	10" Flex Insulated Duct 25'
4028399	10" Oval to Round Adapter

## Items Included in Box:

- Ultra-Aire XT105H Dehumidifier
- Ultra-Aire XT105H Installation Instructions
- Ultra-Aire XT105H Leveling Feet

## ⚠ CAUTION!

**REMOVE COMPRESSOR SHIPPING TIE FROM THE UNIT. FAILURE TO REMOVE SHIPPING TIE WILL CAUSE EXCESS VIBRATION TO BE TRANSMITTED TO THE FRAME.**

## Removal of Compressor Shipping Support

The Ultra-Aire XT105H uses a compressor to power the refrigeration system. To protect the compressor and refrigeration system during shipping, a plastic tie wrap secures it to the unit's frame. Remove the tie wrap by cutting the tie wrap and pulling from the unit as shown. After removing tie wrap, insert plastic plugs provided into the holes.



# DEHUMIDIFIER SET UP

## Important Precautions

- The device is designed to be installed indoors in a space that is protected from rain and flooding.
- Install the unit with enough space to access one of the side panels for maintenance and service.
- Avoid directing the discharge air at people.
- If used near a water source; be certain there is no chance the unit could fall into the water or get splashed and that it is plugged into a dedicated circuit and Ground Fault Circuit Interrupter (GFCI) protected outlet.
- DO NOT use the dehumidifier as a bench or table.
- DO NOT place the dehumidifier directly on structural building members without vibration absorbers or unwanted noise may result. Place the Ultra-Aire XT105H on supports to raise the base of the unit.
- A drain pan MUST be placed under the dehumidifier if installed above a living area or above an area where water leakage could cause damage.

## Location Considerations

- Allow sufficient clearance to handle the unit's overall dimensions as well as the necessary return and supply ductwork to the unit.
- Allow sufficient clearance for filter removal and to prevent airflow obstruction.
- Electrical service access will require the removal of a side panel. Allow sufficient clearance on a side of the unit.
- Locate the dehumidifier in an area where the cord's length (9') easily reaches a 115 VAC electrical outlet with a minimum of a 15 Amp circuit capacity.
- Locate the dehumidifier in an area where field wiring the control (low voltage) to the unit will be possible.
- It is recommended that a backdraft damper be used in the discharge duct of the Ultra-Aire XT105H, especially when connecting to the supply ducting system. The backdraft damper prevents supply air from counter flowing through the Ultra-Aire XT105H when it is not operating. The dehumidifier's location should be chosen to allow installation of this accessory if necessary.
- The Ultra-Aire XT105H may be suspended from structural members with steel hanger straps or a suitable alternative, ensuring the assembly supports the dehumidifier's base in its entirety. DO NOT hang the Ultra-Aire XT105H from its cabinet.
- Allow for proper routing and drainage of needed drain pipes.

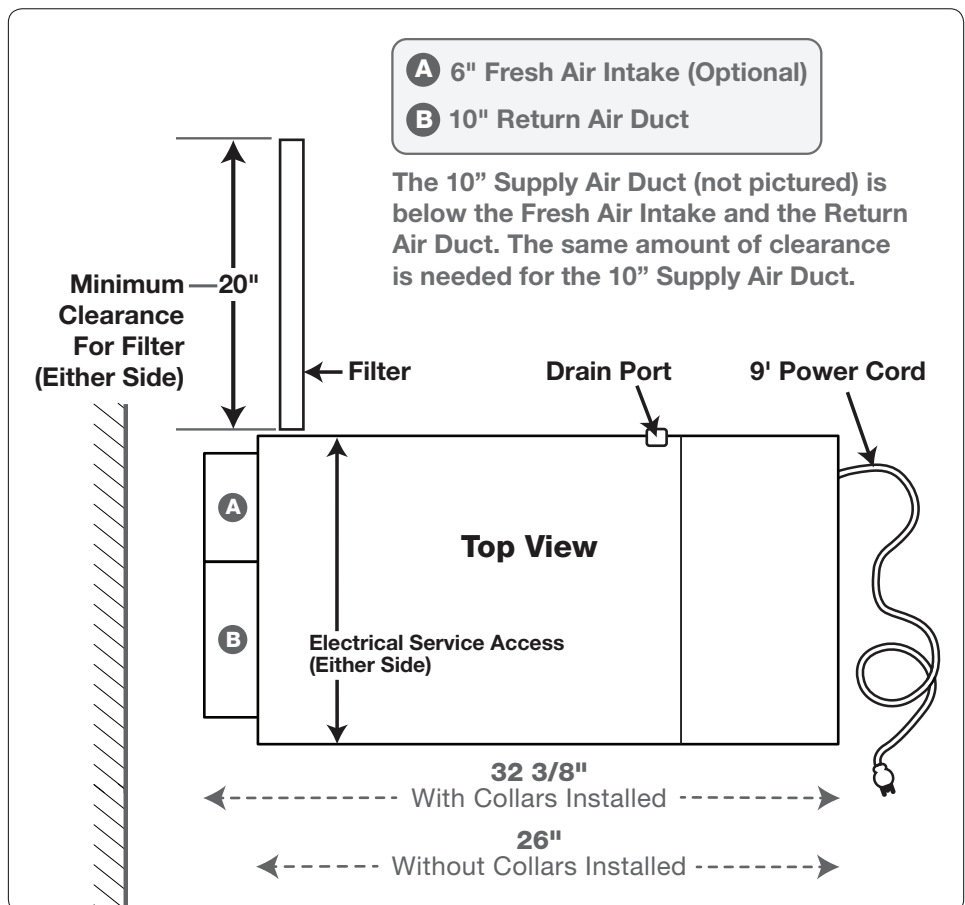

# ATTACHING DUCT COLLARS

## Duct Collar Installation

Remove the two round ducts, oval duct, and oval duct seal and small bag of mounting hardware from inside the rectangle opening.

## Fresh Air Ventilation Duct

Fresh air ventilation is optional. Attach 6" diameter duct to the unit using the screws provided. The 6" duct should be capped if fresh air is not desired. If setting up the unit to provide fresh air ventilation, see page 17.

## Return Air Inlet

Attach 10" diameter duct collar to the unit with the screws provided.

## Supply Air Outlet

Adhere seal onto the back of the oval duct and mount the duct to the front of the dehumidifier using the screws provided.

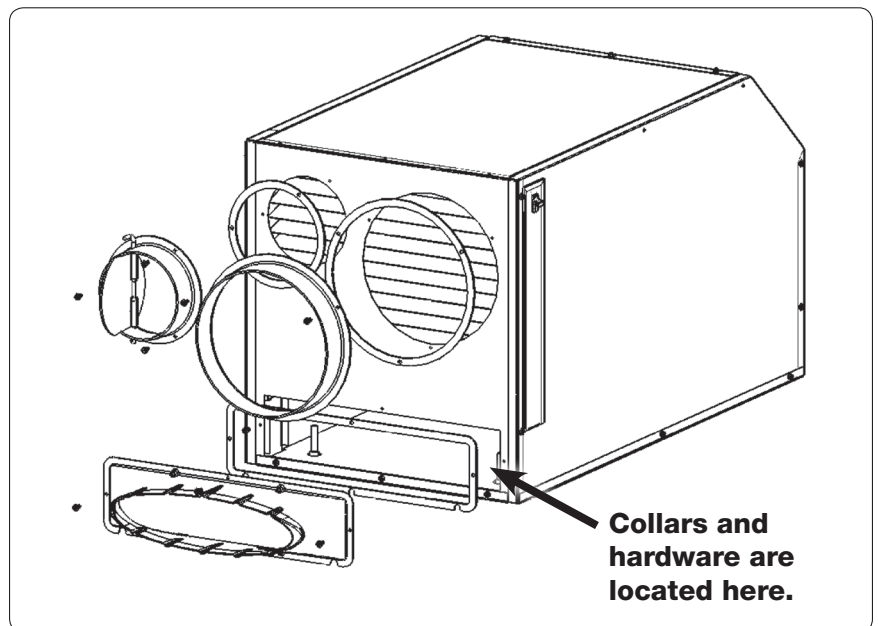
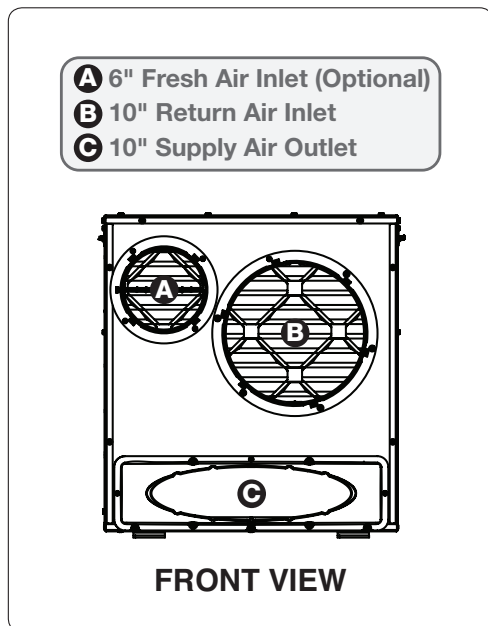

# ELECTRICAL REQUIREMENTS

The Ultra-Aire XT105H plugs into a common grounded 115 VAC outlet. The device draws 4.9 Amps at 80°F and 60% RH. Locate the dehumidifier in an area where the cord's length (9') easily reaches a 115 VAC electrical outlet with a minimum of 15 Amp circuit capacity. If used in an area that may become wet, a GFCI protected circuit is recommended. Consult local electrical codes for further information.

Ultra-Aire offers a variety of control devices for use with the Ultra-Aire XT105H. The control is to be located remotely from the dehumidifier and placed in the space to be conditioned. A low voltage (24 Volt) control MUST be used with the Ultra-Aire XT105H and MUST be connected with low voltage (18-22 gauge) thermostat wire.

## ⚠ WARNING!

**THE REMOTE CONTROLS OF THE ULTRA-AIRE XT105H ARE POWERED BY A LOW VOLTAGE CIRCUIT (24 VAC) AND MUST NEVER CONTACT OR BE CONNECTED TO A HIGH VOLTAGE CIRCUIT.**

## ⚠ CAUTION!

**DO NOT ALLOW THE YELLOW LEAD TO CONTACT THE RED OR WHITE LEAD ON THE ULTRA-AIRE XT105H OR DAMAGE TO THE TRANSFORMER WILL RESULT.**

## ⚠ CAUTION!

**SOME OF THE CONTROL WIRES LEAVING THE ULTRA-AIRE XT105H MAY NOT BE USED WITH CERTAIN CONTROLS AND SHOULD BE LEFT UNCONNECTED WITH WIRE NUTS TAPED ONTO THE STRIPPED ENDS FOR SAFETY.**

### Electrical Precautions

- Do not install the control where it may not accurately sense the relative humidity such as near HVAC supply registers, near exterior doors, on an outside wall, near a window, or near a water source.
- The control wires leaving the Ultra-Aire XT105H and the control are numbered and color-coded to prevent confusion.
- Be sure to consult the electrical schematic in the CONTROLS Section (page 20) of this manual or inside the access panel of the Ultra-Aire XT105H before making control connections.

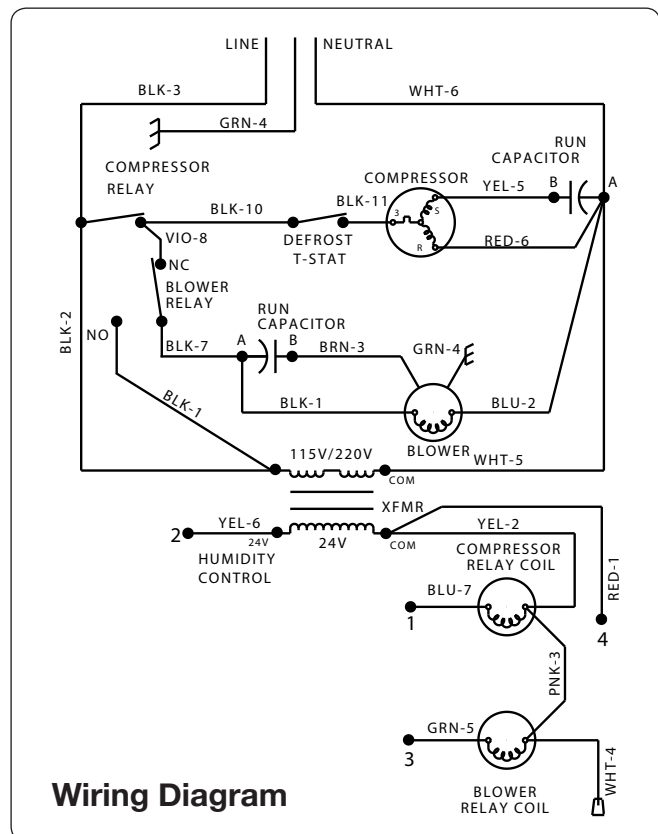



# DRAIN INSTALLATION

The Ultra-Aire XT105H generates condensate.

Place a secondary drain pan under the dehumidifier if it is suspended above a finished area or above an area where water leakage could cause damage.

A drain trap is required for the dehumidifier to drain properly. Install a 3/4" threaded male NPT adapter to the drain pan. Install a drain pipe assembly utilizing 3/4" PVC pipe to transport the condensate to a drain. Pitch of drain should be 1" per 10'.

An optional condensate pump kit is available for use with the Ultra-Aire XT105H and may be installed if lift is required to dispose of condensate. Condensate is automatically pumped to a remote location when the water level in the pump's reservoir rises to close the float switch.

The pump also contains a safety float switch. The white leads from this switch extend from beneath the pump cover. This switch should be installed in series with the field wire that connects to the common lead from the Ultra-Aire XT105H to the control panel. If the pump fails, this switch opens the common control circuit and stops water production before the reservoir overflows. Contact a qualified electrician to install the safety float switch to the Ultra-Aire XT105H dehumidifier.

**Note:** An optional condensate pump kit and an automatic cut-off device can be purchased through your dealer or online.

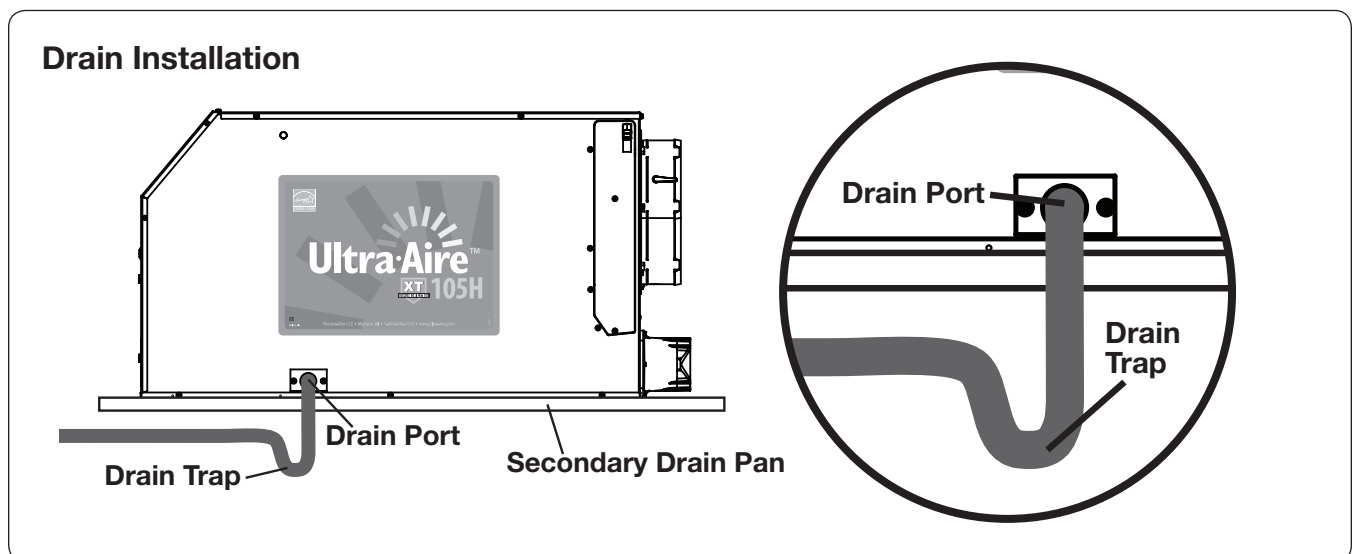

# DUCTING TO HVAC SYSTEMS

The recommended installation creates a separate return for the Ultra-Aire XT105H in a central area of the structure. Duct the supply of the unit to the air supply of the existing HVAC system. Connect an insulated duct from outside to the 6" collar of the Ultra-Aire XT105H to provide fresh make-up air. Adjust the damper in the duct to provide the desired amount of fresh air.

## CAUTION!

**DO NOT CONNECT WITH A STATIC PRESSURE GREATER THAN OR EQUAL TO +0.5 WG. CONTACT TECHNICAL SUPPORT AT 1-800-533-7533 FOR ADDITIONAL DETAILS.**

### Ducting Considerations:

- All flexible ducting connected to the Ultra-Aire XT105H should be UL listed.
- A short piece of flexible ducting on all Ultra-Aire XT105H duct connections is recommended to reduce noise and vibration transmitted to rigid ductwork in the structure.
- Use a minimum 10" diameter round or equivalent rectangular duct for total duct lengths of up to 25'. Use a minimum 12" diameter round or equivalent rectangular duct for longer lengths.
- Grills or diffusers on the duct ends must not excessively restrict airflow.
- A length of 10" or more of insulated flex duct or any other vibration isolating material on the outlet of the Ultra-Aire XT105H will reduce air noise from the blower.
- Effective dehumidification may require that ducting be branched to isolated, stagnant air flow areas. When ducting to two or three areas, use 8" or larger diameter branch ducting. When ducting to four or more areas, use 6" or larger diameter branch ducting. Provisions must be made to provide airflow from supply locations to the central return location. Proper air distribution is important to ensure even humidity control and heat distribution throughout the structure.
- DO NOT locate the return in a bathroom or a kitchen.

# DUCTING TO HVAC SYSTEMS

## Recommended HVAC System Installation

The recommended installation draws air from a dedicated indoor air return and ducts the supply of the dehumidifier to the air supply of the existing HVAC system. Utilize the optional fresh air ventilation duct to provide outside air.

- Install a dedicated 10" air return for the Ultra-Aire XT105H from a central area of the structure.
- Install an insulated duct from outside to the 6" collar of the Ultra-Aire XT105H to provide fresh air ventilation (optional).
- Duct the supply of the Ultra-Aire XT105H to the supply of the existing HVAC system with a backdraft damper.
- If the existing system has multiple returns, instead of installing a dedicated return to the Ultra-Aire XT105H, it is possible to select one to disconnect from the existing HVAC system and use it for the dedicated Ultra-Aire XT105H return. Select a return from a central location in the house that is always open to the rest of the structure. DO NOT use a return from a room where doors are kept closed.
- DO NOT locate return in a bathroom or kitchen.
- Control should be located remotely from the dehumidifier and placed in a central location.

### Attic Installation - Dedicated Ultra-Aire Return to HVAC Supply

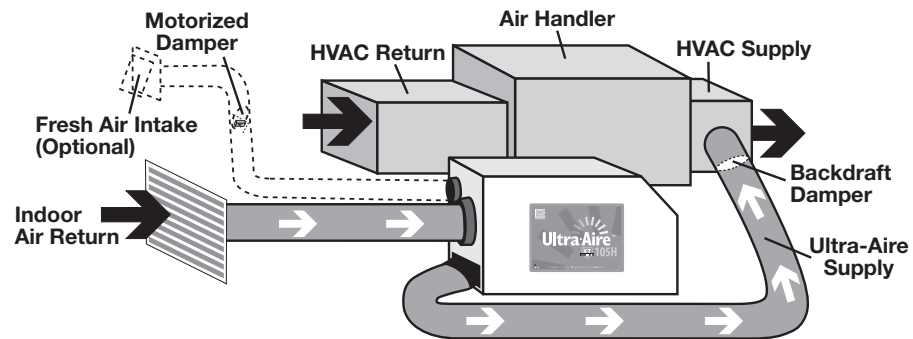

### Basement/Crawlspace Installation - Dedicated Ultra-Aire Return to HVAC Supply

Duct the supply of the Ultra-Aire XT105H to a 10" x 10" x 10" tee damper that is 20 percent open to the basement/crawlspace.

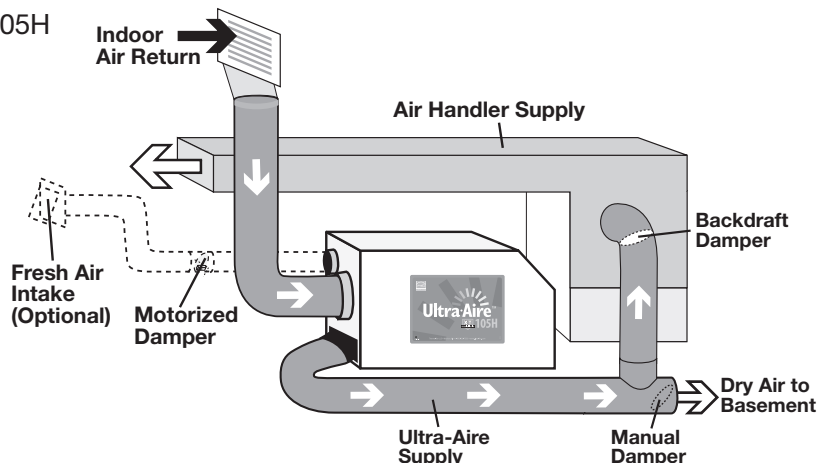

# DUCTING TO HVAC SYSTEMS

## Alternative HVAC System Installations

If the Recommended Dedicated Ultra-Aire Return to HVAC Supply Installation is not possible, there are several alternative installation options available.

- DO NOT locate return in a bathroom or kitchen.
- Control should be located remotely from the dehumidifier and placed in a central location.
- For basement and crawlspace installations, an optional tee can be installed on the Ultra-Aire Supply.

### Dedicated Ultra-Aire Return to HVAC Return

Create a separate return for the Ultra-Aire XT105H in a central area of the building.

Installing the supply air from the Ultra-Aire XT105H to the return of the HVAC system requires the HVAC fan to run when the Ultra-Aire XT105H is operating.

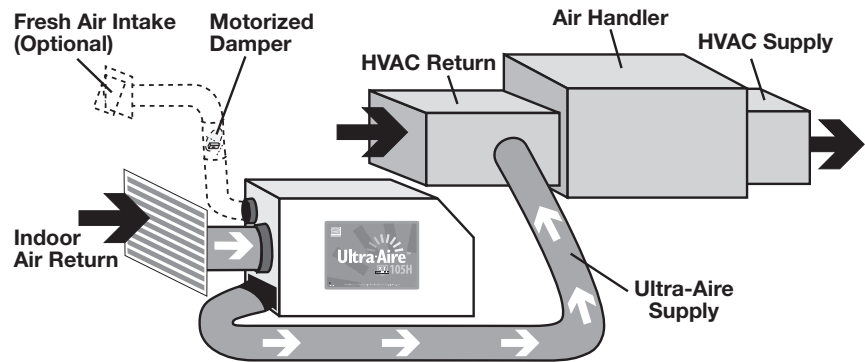

### HVAC Return to HVAC Supply

Check Damper should be in place between the Return and Supply connections of the dehumidifier.

If Check Damper is not in place, the HVAC fan must turn on when the dehumidifier is in operation.

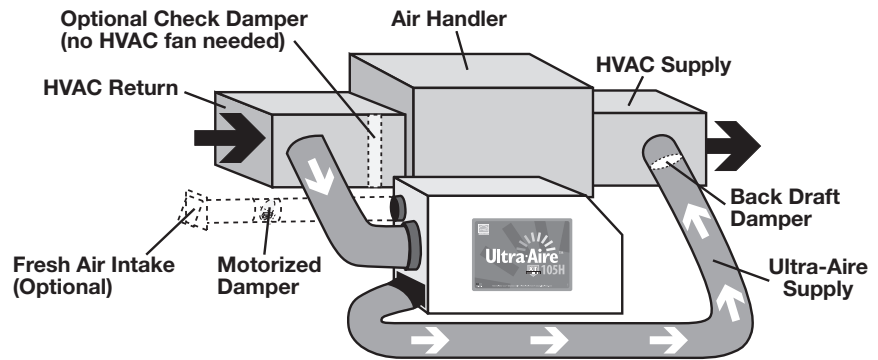

### HVAC Return to HVAC Return

Check Damper should be in place between the Return and Supply connections of the dehumidifier.

If Check Damper is not in place, the HVAC fan must turn on when the dehumidifier is in operation.

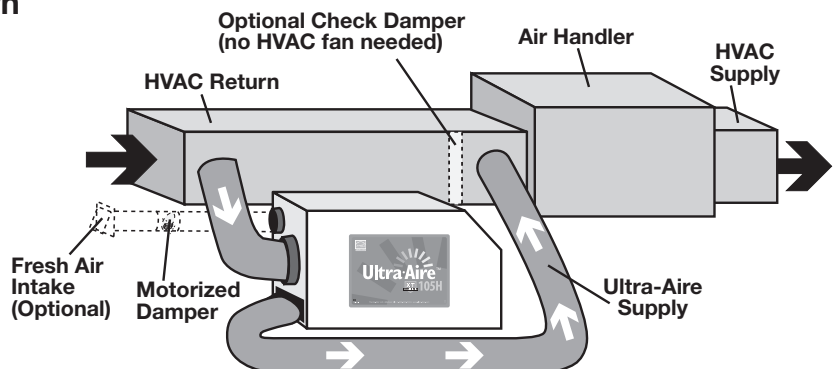

# DUCTING TO HVAC SYSTEMS

## Recommended Multiple HVAC Systems Installation

The Ultra-Aire XT105H can be installed on multiple HVAC systems. Dehumidified air will be provided to both HVAC systems for distribution throughout the structure.

- Backdraft dampers are required in the supply ducts.
- DO NOT locate the return in a bathroom or kitchen.
- One control will service both HVAC zones. Control should be located remotely from the dehumidifiers and placed in a central location.
- HVAC systems should be in close proximity for optimal air flow.
- For multiple systems, contact Technical Support at 1-800-533-7533.

### ⚠ CAUTION!

DO NOT CONNECT WITH A STATIC PRESSURE GREATER THAN OR EQUAL TO +0.5 WG.  
CONTACT TECHNICAL SUPPORT AT 1-800-533-7533 FOR ADDITIONAL DETAILS.

### Dedicated Ultra-Aire Return to Multiple HVAC Systems

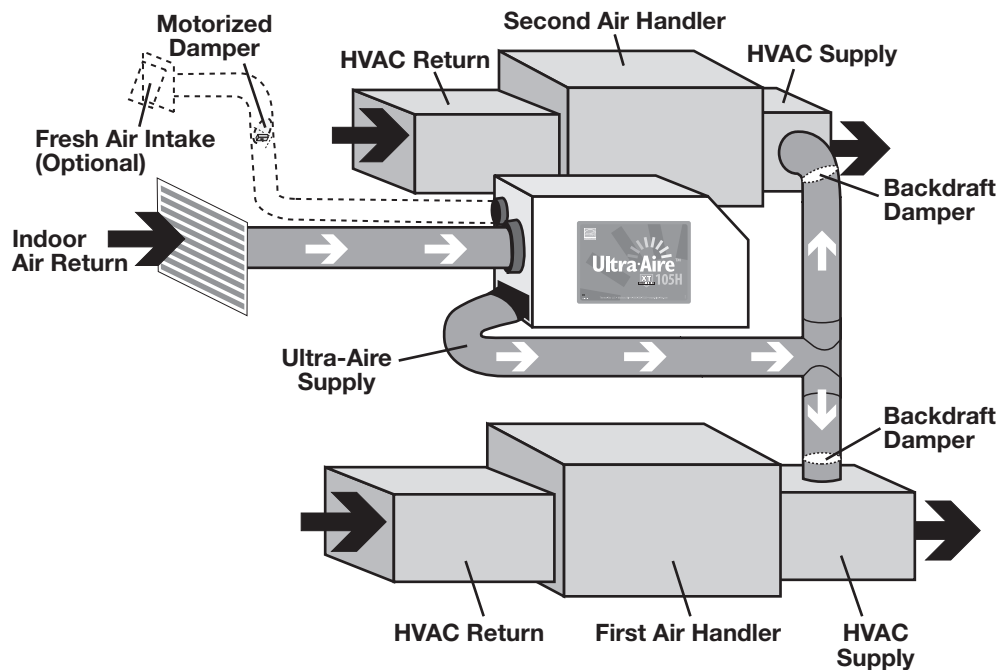

# DUCTING TO HVAC SYSTEMS

## No Existing Ductwork Installation

When installing the Ultra-Aire XT105H in a structure that does not have a forced air HVAC system, a single return for the Ultra Aire XT105H should be installed in a central location.

Install an insulated duct from outside to the 6" collar of the Ultra-Aire XT105H to provide fresh air ventilation (optional).

The supply of the Ultra-Aire XT105H should be ducted to remote areas of the structure such as bedrooms, living room, den, etc. Be sure to utilize multiple rooms to allow air inside the structure to properly circulate. Proper air distribution is important to ensure even humidity control and heat distribution throughout the structure.

A 6" diameter duct is recommended for branches to bedrooms. An 8" diameter duct is recommended for branches to larger areas.

- DO NOT locate the return in a bathroom or kitchen.
- DO NOT locate the supply in rooms where doors may be closed.
- Control should be located remotely from the dehumidifier and placed in a central location.

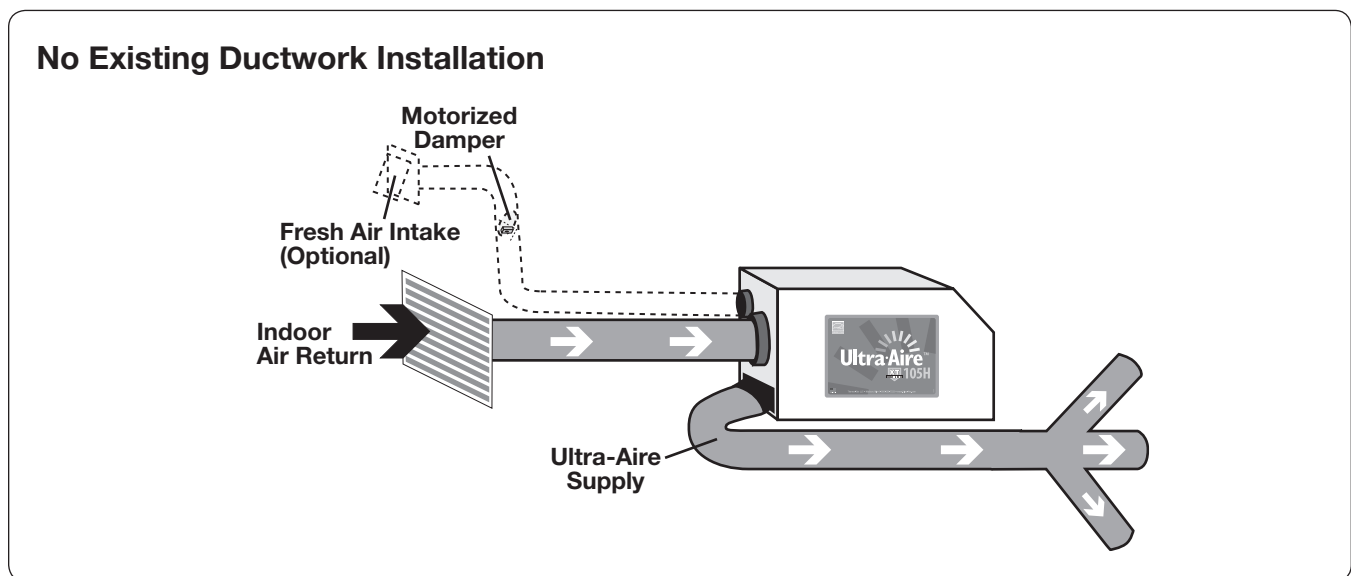

# FRESH AIR VENTILATION

Fresh air ventilation is optional.

Fresh air may be brought into the structure by connecting an insulated duct from outside the structure to the 6" inlet of the Ultra-Aire XT105H. A ventilation control is needed to program the time and frequency that the unit introduces outside air. The time and frequency of ventilation should be based on the size and occupancy of the residence.

- The fresh air ventilation duct should be connected to the 6" round collar on the front of the Ultra-Aire XT105H.
- An insulated 6" diameter duct provides up to 100 CFM of outside air.
- If a motorized damper is not being used, fresh air is controlled by the manual damper in the 6" collar of the Ultra-Aire XT105H. Performance of the Ultra-Aire XT105H can be impacted by inside and outside air conditions.
- When a 6" motorized damper is used, a digital control is required.
- It may be necessary to use 8" duct work if additional fresh air is required.
- In cold climates or at times when the dew point is low, ventilation can be used to dehumidify the structure, making the Ultra-Aire XT105H capable of year-round drying.

## Fresh Air Ventilation With Dehumidifier Off and Fan Only Operation

Outside air mixes with the dehumidifier's return air before being supplied to the home. Outside temperature, inside temperature and relative humidity will impact the combined outlet air conditions.

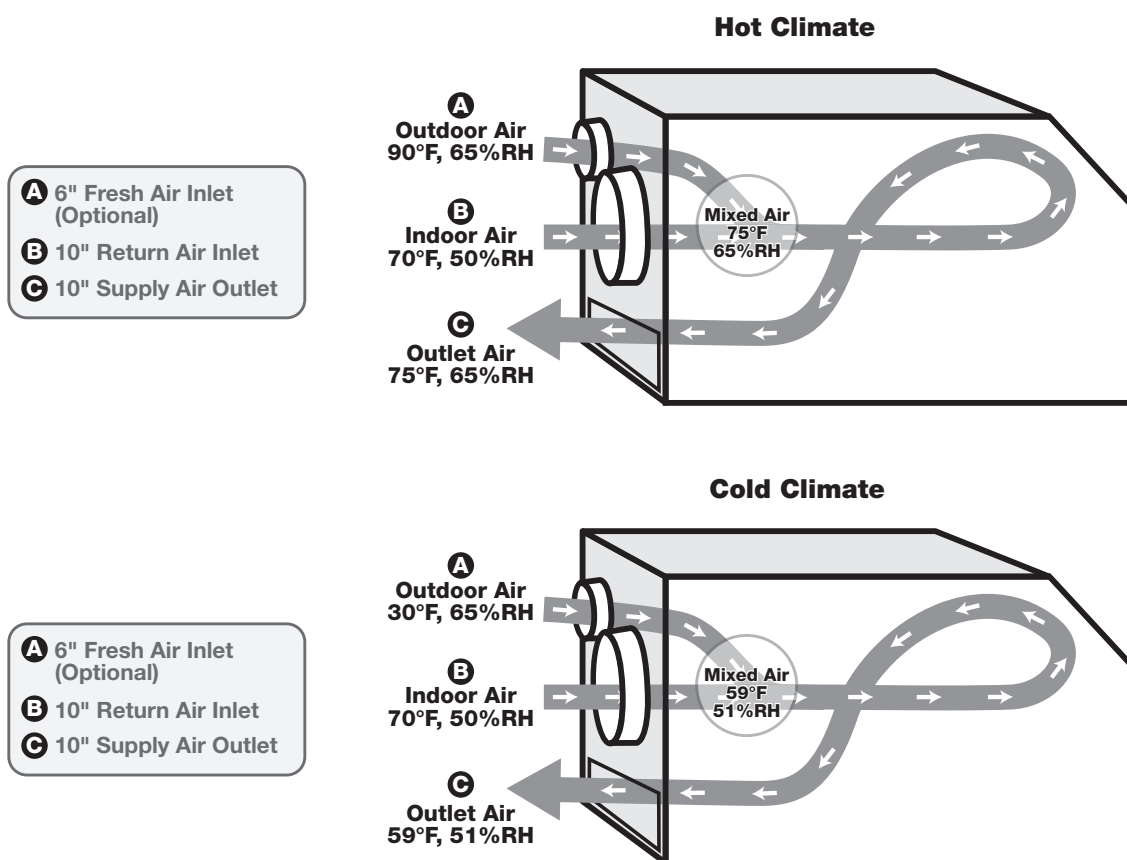

Note: Temperature and relative humidity may vary depending on duct distribution scheme.

# FRESH AIR VENTILATION

## Determine Ventilation Requirements

The MINIMUM ventilation requirement is calculated using ASHRAE 62.2-2010. Use one or both of the options below to determine your ventilation requirement. Follow all local and national building and safety codes.

### Option 1: Calculating Airflow Requirement Using ASHRAE 62.2-2010 Airflow Equation

ASHRAE Airflow in CFM = [House Area in Sq.Ft. x 0.01] + [(Number of Bedrooms + 1) x 7.5]

**NOTE:** Use 'Number of Bedrooms + 1' or 'Number of Occupants', whichever is larger.

**Example 1: Number of Bedrooms + 1**

2500 square foot house with 3 bedrooms, 4 occupants =  $[2500 \times 0.01] + [(3+1) \times 7.5] = 55$  CFM

**Example 2: Number of Occupants**

2500 square foot house with 3 bedrooms, 5 occupants =  $[2500 \times 0.01] + [5 \times 7.5] = 62.5$  CFM

Record the required CFM \_\_\_\_\_

### Option 2: Calculating Airflow Requirement Using Table 4.1 from ASHRAE 62.2-2010

See chart below to find the calculated airflow values to the nearest 5 CFM.

#### Ventilation Air Requirements, CFM

Floor Area (ft <sup>2</sup> )	Number of Bedrooms				
	0-1	2-3	4-5	6-7	>7
< 1500 ft <sup>2</sup>	30	45	60	75	98
1501 - 3000	45	60	75	98	105
3001 - 4500	60	75	98	105	120
4501 - 6000	75	98	105	120	135
6001 - 7500	98	105	120	135	150
> 7500 ft <sup>2</sup>	105	120	135	150	165

Table 4.1 from ASHRAE 62.2-2010

Record the required CFM \_\_\_\_\_



A control must be used with the Ultra-Aire XT105H. Ultra-Aire offers the DEH 3000 proprietary control. The DEH 3000 allows homeowners to monitor and control relative humidity and proper ventilation levels in their home. This control is also available with a remote sensing option.

**Note:** The DEH 3000 is sold separately and can be purchased through your local dealer or online. Other thermostats are compatible with the Ultra-Aire XT105H.

## Ultra-Aire DEH 3000 Digital Control

- **Central Fan Integration** – Operates HVAC fan with dehumidifier operation.
- **A/C Sensor** – Automatically activates or deactivates the dehumidifier when the air conditioner runs.
- **High Temperature Cut-Out** – Disables dehumidifier operations if household temperature reaches the cut-out setpoint.
- **Dry-Out Cycle Timer** – Automatic fan cycling to ensure dry and clean coils.
- **Auto Reboot** – Resumes operation with prior settings in the event of power failure.

**See DEH 3000 manual for detailed instructions.**

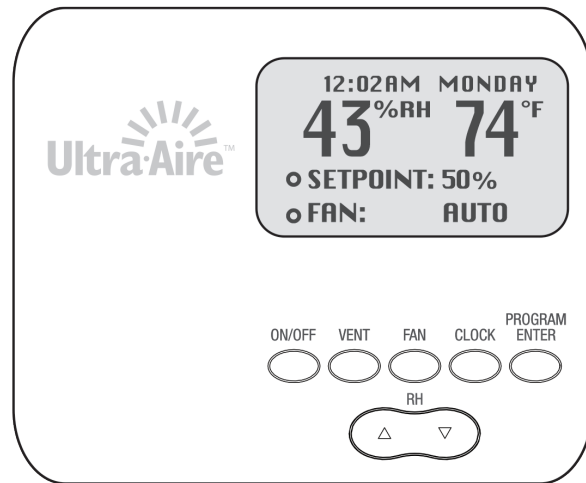

## Wiring Controls

### ⚠ CAUTION!

**DO NOT ALLOW THE YELLOW LEAD FROM THE ULTRA-AIRE XT105H TO CONTACT THE RED LEAD OR THE WHITE LEAD FROM THE ULTRA-AIRE XT105H OR DAMAGE TO THE TRANSFORMER WILL RESULT.**

**DO NOT CONNECT THE WHITE WIRE TO THE CONTROL IF THE OPTIONAL DAMPER IS NOT USED OR DAMAGE TO THE TRANSFORMER WILL RESULT.**

## Control Connections

The control and the control wires leaving the Ultra-Aire XT105H are numbered and color-coded to prevent confusion. Depending on the control, some of the wires leaving the Ultra-Aire XT105H may not be used. For safety, the unconnected wires should be covered with wire nuts. Be sure to consult the electrical schematic in this manual or inside the access panel of the Ultra-Aire XT105H before making control connections.

# CONTROLS

A low voltage control must be used with the Ultra-Aire XT105H.

<b>Five Color Coded Wires Control Operation</b>	
<b>Green (or brown)</b>	<b>Fan control</b>
<b>Blue</b>	<b>Dehumidification (fan and compressor) control</b>
<b>Red</b>	<b>24 VAC power transformer neutral side (common with white)</b>
<b>White</b>	<b>24 VAC power transformer neutral side (common with red)</b>
<b>Yellow</b>	<b>Transformer high side</b>

Between the red/white lead and the yellow lead is a 40VA transformer. This low voltage power source powers the relay coils which control the fan and compressors. This 24 VAC transformer can also be used to power HVAC accessories external to the dehumidifier.

<b>Unit ON &amp; Fan ON</b>	<b>Make contact between yellow and blue wires</b>
<b>Unit OFF / Fan On</b>	<b>Make contact between yellow and green (or brown) wires</b>
<b>Power HVAC Accessory</b>	<b>Connect the accessory to the white (or red) wire and the yellow wire</b>

## Basic Control Wiring

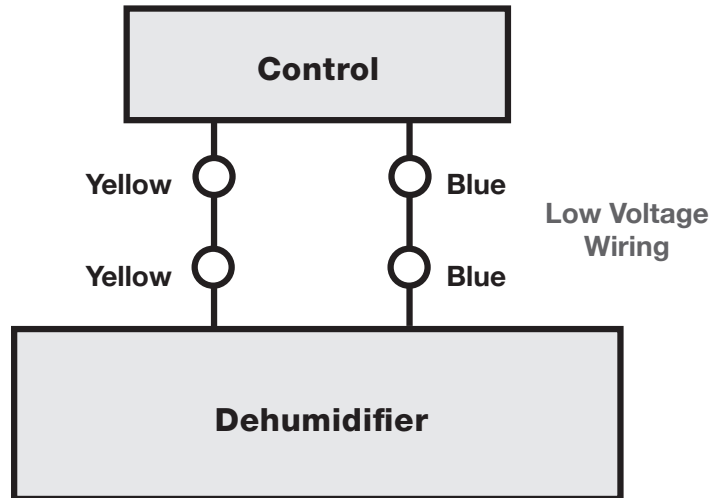

# AIR FILTRATION

The Ultra-Aire XT105H is equipped with a MERV-11 filter. An optional MERV-14 filter and filter housing is available at [www.UltraAireFilters.com](http://www.UltraAireFilters.com). The filter should be checked and replaced every three to six months. Operating the unit with a dirty filter will reduce dehumidifier capacity and efficiency.

DO NOT operate the unit without the recommended filter. Filter non-compliance voids the product warranty.

## ⚠ CAUTION!

**MAKE SURE UNIT IS OFF BEFORE CHANGING THE FILTER.**

### Changing the Filter

For greatest filtration and efficiency of the Ultra-Aire XT105H, it is recommended the air filter be replaced every three to six months with a MERV-11 filter.

**Step 1:** Release the latch from the cabinet by pulling it down and out. Remove the filter door by pulling it out of the bottom tab.

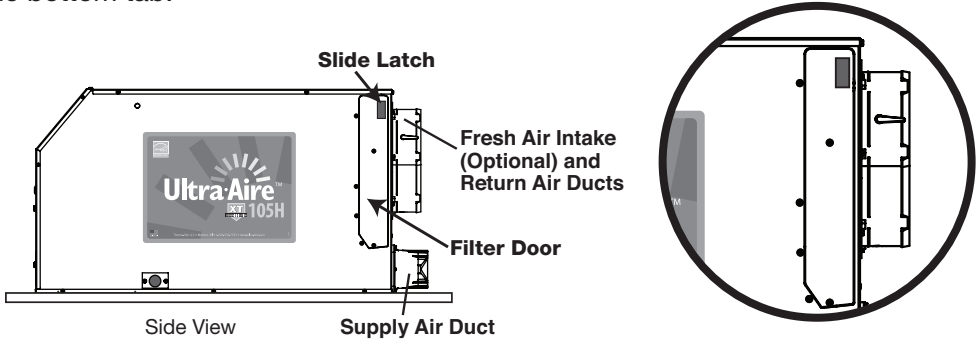

**Step 2:** Remove the filter by gently pulling it straight out of the unit. Insert new filter by gently pushing it straight into the unit. Make sure the AIR FLOW arrow on the filter is pointing into the unit.

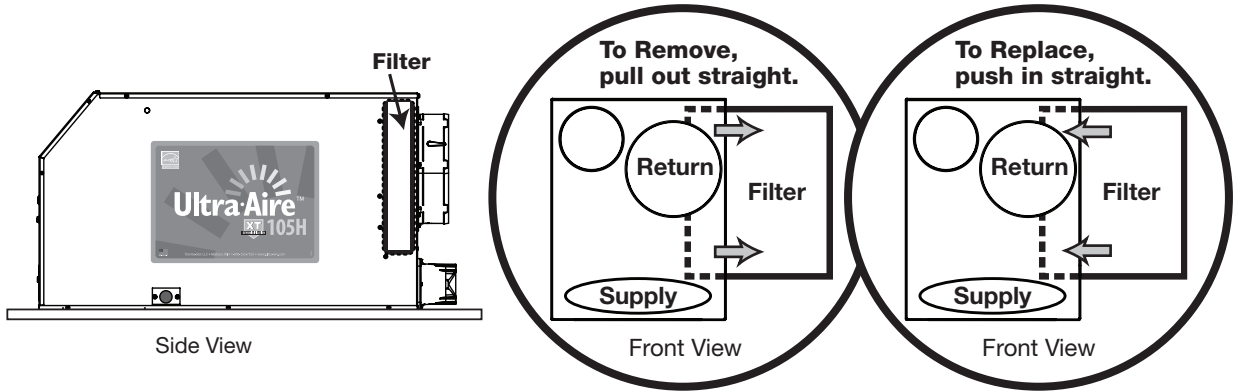

**Step 3:** Insert filter door into bottom tab. Push latch down and swing door shut. Once the door is shut, release the latch.

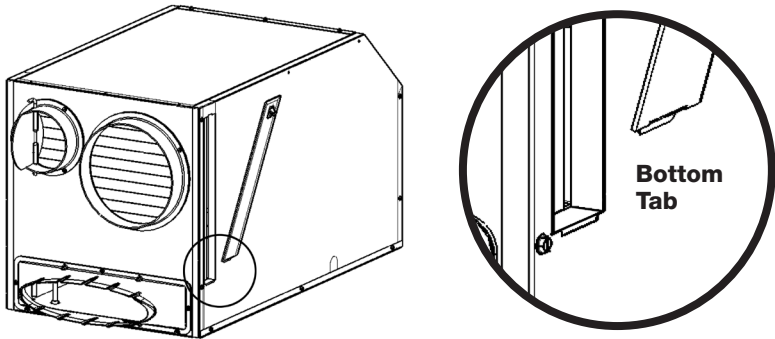

# AIR FILTRATION

## MERV Rating Chart

Standard 52.5 Minimum Efficiency Reporting Value	Dust Spot Efficiency	Arrestance	Typical Controlled Contaminant	Typical Applications and Limitations	Typical Air Filter/Cleaner Type
20	n/a	n/a	< 0.30 pm particle size	Cleanrooms	>99.999% eff. On .10-.20 pm Particles
19	n/a	n/a	Virus (unattached)	Radioactive Materials	Particles
18	n/a	n/a	Carbon Dust	Pharmaceutical Man.	Particulates
17	n/a	n/a	All Combustion smoke	Carcinogenetic Materials	>99.97% eff. On .30 pm Particles
16	n/a	n/a	.30-1.0 pm Particle Size	General Surgery	Bag Filter - Nonsupported
15	>95%	n/a	All Bacteria	Hospital Inpatient Care	microfine fiberglass or synthetic media, 12-36 in. deep, 6-12 pockets.
14	90-95%	>98%	Most Tobacco Smoke	Smoking Lounges	Box Filter - Rigid Style Cartridge Filters 6 to 12" deep may use lofted or paper media.
13	89-90%	>98%	Proplet Nuceli (Sneeze)	Superior Commercial Buildings	
12	70-75%	>95%	1.0-3.0 pm Particle Size Legionella	Superior Residential	Bag Filter - Nonsupported microfine fiberglass or synthetic media, 12-36 in. deep, 6-12 pockets.
11	60-65%	>95%	Humidifier Dust Lead Dust	Better Commercial Buildings	
10	50-55%	>95%	Milled Flour Auto Emissions	Hospital Laboratories	Box Filter - Rigid Style Cartridge Filters 6 to 12" deep may use lofted or paper media.
9	40-45%	>90%	Welding Fumes		
8	30-35%	>90%	3.0-10.0 pm Particle Size	Commercial Buildings	Pleated Filters - Disposable, extended surface area, thick with cotton-polyester blend media, cardboard frame.
7	25-30%	>90%	Mold Spores Hair Spray	Better Residential	Cartridge Filters - Graded density viscous coated cube or pocket filters, synthetic media.
6	<20%	85-90%	Fabric Protector Dusting Aids	Industrial Workplace	Throwaway - Disposable synthetic panel filter
5	<20%	80-85%	Cement Dust Pudding Mix	Paint Booth Inlet	
4	<20%	75-80%	>10.0 pm Particle Size	Minimal Filtration	Throwaway - Disposable fiberglass or synthetic panel filter
3	<20%	70-75%	Pollen Dust Mites	Residential	Washable - Aluminum Mesh.
2	<20%	65-70%	Sanding Dust Spray Paint Dust		
1	<20%	<65%	Textile Fibers Carpet Fibers	Window A/C Units	Electrostatic - Self charging woven panel filter.

Table Data Source: United States Environmental Protection Agency

## Service Parts List

Item	Part No.	Description
1	4021475	Air Filter 16"x20"x2" MERV-11
2	4026221	Foot, Leveling, 5/16-18
3	4031085	Condenser Coil
4	4031086-02	E-coat Evaporator Coil
5	4029510	Filter/Drier
6	4025741	Thermostat, Defrost Control
7	4032226	Compressor Replacement Kit
8	4029568	Compressor Overload
9	4026657	Impeller
9	4031917	Compressor Capacitor, 45 MFD, 370V, Oil
10	4031924	Blower Capacitor, Run, 15 MFD, 370V, Dry
11	4020924	Blower Relay, SPDT, 24V, 15A
12	4022484	Compressor Relay, SPST, 24V, 30A
13	4022487	Transformer

## Refrigerant Charging

### **WARNING!**

**SERVICING THE ULTRA-AIRE XT105H WITH ITS HIGH PRESSURE REFRIGERANT SYSTEM AND HIGH VOLTAGE CIRCUITRY PRESENTS A HEALTH HAZARD WHICH COULD RESULT IN DEATH, SERIOUS BODILY INJURY, AND/OR PROPERTY DAMAGE. SERVICE MUST BE PERFORMED BY A QUALIFIED SERVICE TECHNICIAN.**

If the refrigerant charge is lost due to service or a leak, the leak should be repaired and a new charge must be accurately weighed in. If any of the old charge is left in the system, it must be recovered before weighing in the new charge. Refer to the unit nameplate for the correct charge weight and refrigerant type.

# SERVICE

## Troubleshooting

### **⚠ CAUTION!**

**TROUBLESHOOTING SHOULD BE PERFORMED BY A QUALIFIED HVAC TECHNICIAN.**

Symptom	Possible Reason	Troubleshooting Procedure
Neither fan nor compressor running. Dehumidification is being called for.	<ol style="list-style-type: none"> <li>1. Dehumidifier unplugged or no power to outlet.</li> <li>2. Humidity control set too high.</li> <li>3. Loose connection in internal or control wiring.</li> <li>4. Defective compressor relay.</li> <li>5. Defective control transformer.</li> </ol>	<div style="border: 1px solid black; padding: 5px; margin-bottom: 10px;"> <p><b>⚠ WARNING!</b></p> <p><b>ELECTRICAL SHOCK HAZARD: ELECTRICAL POWER MUST BE PRESENT TO PERFORM SOME TESTS. THESE TESTS SHOULD BE PERFORMED BY A QUALIFIED SERVICE PERSON.</b></p> </div> <p><b>Troubleshooting Procedure for Control Related Issues</b></p> <p>This method of diagnosis will test the 3 main components of the control circuit individually to indicate any potential problems. This is to be used when the control will not activate the main unit.</p> <ol style="list-style-type: none"> <li>1. Detach field control wiring connections from the pigtails on the main unit.</li> <li>2. Connect the yellow and green wire pigtails together; only the fan should run. Disconnect the wires.</li> <li>3. Connect the yellow and blue wires pigtails together; fan and compressor should run. Disconnect the wires.</li> <li>4. If this test works, the main unit is working correctly from a control standpoint.</li> <li>5. Reconnect field control wiring to the pigtails on the main unit.</li> <li>6. Remove the control panel cover and detach the field wiring from the control connections.</li> <li>7. Connect the yellow and green wires together; only the fan should run. Disconnect the wires.</li> <li>8. Connect the yellow and blue wires together; fan and compressor should run. Disconnect the wires.</li> <li>9. If this test works, then the field control wiring is ok.</li> <li>10. If the problem persists, then the control is most likely faulty.</li> </ol>
Compressor is not running. Dehumidification is being called for. Fan is running.	<ol style="list-style-type: none"> <li>1. Defective compressor run capacitor.</li> <li>2. Loose connection in compressor circuit.</li> <li>3. Defective compressor overload.</li> <li>4. Defective compressor.</li> <li>5. Defrost thermostat open.</li> </ol>	
Compressor cycles on and off. Dehumidification is being called for.	<ol style="list-style-type: none"> <li>1. Low ambient temperature and/or humidity causing unit to cycle through defrost mode.</li> <li>2. Defective compressor overload.</li> <li>3. Defective compressor.</li> <li>4. Defrost thermostat defective.</li> <li>5. Dirty air filter(s) or air flow restricted.</li> <li>6. Defective fan or relay.</li> </ol>	

## Troubleshooting (Continued)

Symptom	Possible Reason	Troubleshooting Procedure
Fan is not running. Dehumidification or fan is being called for.	<ol style="list-style-type: none"> <li>1. Loose connection in fan circuit.</li> <li>2. Obstruction prevents fan impeller rotation.</li> <li>3. Defective fan.</li> <li>4. Defective fan relay.</li> </ol>	<div style="border: 1px solid black; padding: 5px; margin-bottom: 10px;"> <p><b>⚠ WARNING!</b></p> <p><b>ELECTRICAL SHOCK HAZARD: ELECTRICAL POWER MUST BE PRESENT TO PERFORM SOME TESTS. THESE TESTS SHOULD BE PERFORMED BY A QUALIFIED SERVICE PERSON.</b></p> </div> <p><b>Troubleshooting Procedure for Performance Related Issues</b></p> <p>This method of diagnosis is used to function check the internal components in the dehumidifier. This is to be used when a performance issue is suspected.</p> <ol style="list-style-type: none"> <li>1. Set the humidity controller all the way to the most humid setting or off position – Did the unit shut off?</li> <li>2. If yes, turn the fan setting to the ON position – does the fan start?</li> <li>3. If fan starts, leave in the fan ON position and set the humidity all the way to driest setting. May have to wait 5 minutes for the compressor to start.</li> <li>4. Listen for a distinct buzzing/humming sound of a compressor starting up – do you hear this noise?</li> <li>5. If compressor is running and continues to run, after about 15 minutes you should feel a slight increase in air temperature being discharged out of the discharge air side of the unit.</li> <li>6. If so, depending on your environmental conditions (temp/Rh%), you should see some water production out of the hose within 30 minutes or so. <i>(Note: If the room temperature is 55 degrees or below and/or in area of low relative humidity, the dehumidifier will produce little to no water.)</i></li> <li>7. Collecting the water removed in a 24 hour period will give a measurement of performance.</li> </ol>
Low dehumidification capacity (evaporator is frosted continuously). Dehumidification is being called for.	<ol style="list-style-type: none"> <li>1. Defrost thermostat loose or defective.</li> <li>2. Low refrigerant charge.</li> <li>3. Dirty air filter(s) or air flow restricted.</li> <li>4. Excessively restrictive ducting connected to unit.</li> </ol>	
No ventilation. Ventilation is being called for.	<ol style="list-style-type: none"> <li>1. Loose connection in ventilation control circuit.</li> <li>2. Loose connection in damper power circuit.</li> <li>3. Defective fresh air damper.</li> </ol>	
Dehumidifier removes some water, but not as much as expected.	<ol style="list-style-type: none"> <li>1. Air temperature and/or humidity have dropped.</li> <li>2. Humidity meter and or thermometer used are out of calibration.</li> <li>3. Unit has entered defrost cycle.</li> <li>4. Dirty air filter(s) or air flow is restricted.</li> <li>5. Defective defrost thermostat.</li> <li>6. Low refrigerant charge.</li> <li>7. Air leak such as loose cover or ducting leaks.</li> <li>8. Defective compressor.</li> <li>9. Restrictive ducting.</li> </ol>	

# WARRANTY

**Limited Warranty.** Therma-Stor, LLC (“Therma-Stor”) warrants as follows: (i) the Ultra-Aire XT105H dehumidifier (“Product”) will be free of material defects in workmanship or materials for a period of one (1) year (“One-Year Warranty”) following the date of initial purchase of such Product by an original customer purchasing from Therma-Stor or an authorized reseller (“Customer”); and (ii) the Product’s condenser, evaporator, and compressor will be free of material defects in workmanship or materials for a period of five (5) years following the date of initial purchase of such Product by a Customer.

**Limitation of Remedies.** CUSTOMER’S SOLE AND EXCLUSIVE REMEDY UNDER THE ABOVE LIMITED WARRANTY AND THERMA-STOR’S ENTIRE LIABILITY THEREUNDER, SHALL BE, AT THE SOLE OPTION OF THERMA-STOR, REPLACEMENT OR REPAIR OF SUCH PRODUCT OR ITS COMPONENTS (“COMPONENTS”) BY THERMA-STOR OR THERMA-STOR’S AGENTS ONLY. REFRIGERANT, PIPING, SUPPLIES, TRANSPORTATION COSTS, LABOR COSTS INCURRED IN REPAIR OR REPLACEMENT OF SUCH COMPONENTS ARE NOT INCLUDED. THIS DISCLAIMER AND EXCLUSION SHALL APPLY EVEN IF THE EXPRESS WARRANTY AND LIMITED REMEDY SET FORTH HEREIN FAILS OF ITS ESSENTIAL PURPOSE. CUSTOMER ACKNOWLEDGES THAT NO REPRESENTATIVE OF THERMA-STOR OR OF ITS AFFILIATES OR RESELLERS IS AUTHORIZED TO MAKE ANY REPRESENTATION OR WARRANTY ON BEHALF OF THERMA-STOR OR ANY OF ITS AFFILIATES OR RESELLERS THAT IS NOT IN THIS AGREEMENT. Notwithstanding the above, during the term of the One-Year Warranty only, Therma-Stor will provide, free of charge to Customer, all Components and labor (except costs related to removal and installation of Product) required to fulfill its obligations under such One-Year Warranty.

**Disclaimer of Warranties.** EXCEPT FOR ABOVE LIMITED WARRANTY, WHICH IS THE SOLE AND EXCLUSIVE WARRANTY PROVIDED WITH RESPECT TO THE PRODUCT AND ITS COMPONENTS, THERMA-STOR HEREBY DISCLAIMS ALL EXPRESS AND IMPLIED WARRANTIES, INCLUDING, WITHOUT LIMITATION, THE IMPLIED WARRANTIES OF MERCHANTABILITY AND FITNESS FOR A PARTICULAR PURPOSE.

**Warranty Limitations.** The foregoing limited warranty extends only to a Customer and shall be null and void upon attempted assignment or transfer. A “defect” under the terms of the limited warranty shall not include problems resulting from Customer’s or Customer’s employees’, agents’, invitees’ or a third party’s misuse, improper installation, improper design of any system in which the Product is included, abuse, lack of normal care, failure to follow written instructions, tampering, improper repair, or freezing, corrosion, acts of nature or other causes not arising out of defects in Therma-Stor’s workmanship or material. If a Product or Component is replaced while under warranty, the applicable limited warranty period shall not be extended beyond the original warranty time period. The limited warranty does not cover any costs related to changes to a Product or Component that may be required by any codes, laws, or regulations that may become effective after initial purchase of the Product by Customer.

**Customer Responsibilities.** As a further condition to obtaining warranty coverage hereunder, the Customer must send a valid warranty claim to Therma-Stor such that Therma-Stor receives such claim prior to the end of the applicable warranty period. Therma-Stor shall have no obligation hereunder with respect to any claim received by Therma-Stor after the expiration of the applicable warranty period. As a further condition to obtaining warranty coverage hereunder, the Customer must present forms of invoices evidencing proof of purchase of a Product. If such invoices do not clearly indicate the date of initial purchase by a Customer, the applicable Product’s date of manufacture will be used instead of the date of initial purchase for the purpose of calculating the commencement of the applicable warranty period. Warranty service must be performed by Therma-Stor or a servicer authorized by Therma-Stor. In order to obtain warranty service, the Customer should call Therma-Stor at 1-800-533-7533 and ask for the Therma-Stor Products Service Department, which will then arrange for applicable warranty service. Warranty service will be performed during customary, daytime working hours. If the Product must be shipped for service, Customer shall be solely responsible for properly packaging the Product, for all freight charges, and for all risk of loss associated with shipment.

**Limitation of Liability.** IN NO EVENT SHALL THERMA-STOR, IN CONNECTION WITH THE DESIGN, SALE, INSTALLATION, USE, REPAIR, REPLACEMENT OR PERFORMANCE OF ANY PRODUCT, COMPONENT, PART THEREOF OR WRITTEN MATERIAL PROVIDED THEREWITH, BE LIABLE, TO THE EXTENT ALLOWED UNDER APPLICABLE LAW, UNDER ANY LEGAL THEORY FOR ANY SPECIAL, DIRECT, INDIRECT, COLLATERAL OR CONSEQUENTIAL DAMAGES OF ANY KIND. NOTWITHSTANDING THE ABOVE LIMITATIONS AND WARRANTIES, THE SOLE AND EXCLUSIVE LIABILITY OF THERMA-STOR, REGARDLESS OF THE NATURE OR THEORY OF THE CLAIM, SHALL UNDER NO CIRCUMSTANCES EXCEED THE PURCHASE PRICE OF THE PRODUCT, COMPONENT OR PART UPON WHICH THE CLAIM IS PREMISED.

**Applicable Law and Venue.** ANY ARBITRATION, ENFORCEMENT OF AN ARBITRATION OR LITIGATION RELATED TO THE PRODUCT WILL BE BROUGHT EXCLUSIVELY IN DANE COUNTY, WISCONSIN, AND CUSTOMER CONSENTS TO THE JURISDICTION OF THE FEDERAL AND STATE COURTS LOCATED THEREIN, SUBMITS TO THE JURISDICTION THEREOF AND WAIVES THE RIGHT TO CHANGE VENUE. CUSTOMER FURTHER CONSENTS TO THE EXERCISE OF PERSONAL JURISDICTION BY ANY SUCH COURT WITH RESPECT TO ANY SUCH PROCEEDING.

**Miscellaneous.** If any term or condition of this Limited Warranty is found by a court of competent jurisdiction to be invalid, illegal or otherwise unenforceable, the same shall not affect the other terms or conditions hereof or thereof or the whole of this Limited Warranty. Any delay or failure by Therma-Stor to exercise any right or remedy will not constitute a waiver of Therma-Stor to thereafter enforce such rights.











1-800-533-7533  
[www.Ultra-Aire.com](http://www.Ultra-Aire.com)