



Ultra-Aire 150H Whole House Ventilating Dehumidifier

UA-150H • Part No. 4024371 • Serial No. _____



Dehumidification

The highly efficient Ultra-Aire 150H dehumidifier utilizes refrigeration to cool the incoming air stream below its dew point. This cooled and drier air is used to pre-cool the incoming air stream resulting in a significant increase in overall efficiency. After the pre-cooling stage, the processed air is reheated by passing through the condenser coil. The heat removed by the evaporator coil is returned to the air stream, resulting in an overall temperature increase of the air leaving the unit.

The Ultra-Aire 150H is controlled by 24 volt remote wired controls. A variety of controls are available suitable to various applications.

Fresh Air Ventilation

Optional fresh outdoor air may be ducted to the unit via a six inch round duct. This provides fresh air to dilute pollutants and maintain high oxygen content in the air. The amount of fresh air ventilation can be regulated by a variety of dampers and controls.

Air Filtration

The UA-150H includes air filtration to improve indoor air quality. A MERV-11 media filter is standard. An optional MERV-14 deep pleated 95% media filter is available for optimum air filtration and to reduce potentially harmful airborne particles. If the optional filter is chosen, the standard filter operates as a prefilter.

HVAC INSTALLER: PLEASE LEAVE MANUAL FOR HOMEOWNER

TABLE OF CONTENTS

Table of Contents

Safety Precautions.....	3	5.3H Damper Operation and Setting	13
1. Intended Application	4	5.3I Intermittent/Programmed Ventilation	14
2. Specifications	4	5.3J Programming Notes	14
3. Installation	4	5.3K Ventilating or Dehumidifying to Control	
3.1 Location	4	Indoor Relative Humidity Levels	14
3.2 Electrical Requirements.....	4	5.3L Stop Start	14
3.3 Condensate Removal.....	5	5.3M Low Pressure Control	14
3.4 Ducting.....	5	6. Maintenance.....	15
3.4A Installing Duct Collars	5	6.1 Standard Air Filter.....	15
3.4B Ducting for Dehumidification	5	6.2 High Efficiency Air Filter	15
3.4C Ducting for Fresh Air.....	6	6.3 Impeller Fan Oiling.....	15
3.4D Installation in a Basement	6	6.4 Fresh Air Return	15
3.4E Installation in a attic	7	7. Service	15
3.4F Installation with (2) HVAC systems	7	7.1 Warranty	15
3.4G Installation without an HVAC system.....	7	7.2 Technical description	15
3.5 Quiet Installation.....	7	7.3 Troubleshooting	16
4. Controls	7	7.4 Refrigerant Charging	17
4.1 Humidity/Fan Control Panel.....	7	7.5 Impeller Fan Replacement	17
4.2 Ventilation Timer & Humidity Control Panel	8	7.6 Compressor/Capacitor Replacement.....	17
4.3 Humidity Control Adjustment	8	7.6A Checking Compressor Motor Circuits	17
4.4 Fan/Filter Switch.....	8	7.6B Replacing Burned Out Compressor	17
4.5 Ventilation Timer.....	8	7.6C Replacing Compressor-Nonburn Out.....	18
4.6 Low Pressure Control	9	7.7 Remote Controls.....	18
DEH Wiring Diagram	10	7.7A Humidity Control.....	18
5. DEH 2000 Digital Control	11	7.7B Ventilation Timer.....	18
5.1 Specifications	11	7.8 Defrost Thermostat.....	18
5.2 Installation	11	7.9 Electric Ventilation Damper	18
5.2A Install Instructions	11	7.10 Low Pressure Control	19
5.2B Wiring	11	7.11 Condensate Pump Kit	19
5.2C Location	12	Electrical Schematic	19
5.3 Operation	12	Pictorial Electrical Diagram.....	20
5.3A Display	12	Wiring Diagrams.....	21
5.3B Setting	12	Service Parts List	22
5.3C On/Off Setting	12	Optional Parts List	23
5.3D Setting Clock Time	12	Vibration Isolation Kit:.....	24
5.3E Setting Relative Humidity Set point	13	External Insulation Kit.....	25, 26
5.3F Fan Setting and Operation	13	Warranty.....	27
5.3G Fan On Fan Off Fan Program	13		

SAFETY PRECAUTIONS

1. Safety Precautions

Read the installation, operation and maintenance instructions carefully before installing and operating this device. Proper adherence to these instructions is essential to obtain maximum benefit from your UA-150H indoor air quality system.

READ AND SAVE THESE INSTRUCTIONS

- The device is designed to be installed INDOORS IN A SPACE THAT IS PROTECTED FROM RAIN AND FLOODING.
- Install the unit with space to access the front panel for maintenance and service. DO NOT INSTALL UNIT WITH THE FRONT PANEL INACCESSIBLE.
- Avoid directing the discharge air at people, or over the water in pool areas.
- If used near a pool or spa; be certain there is NO chance the unit could fall into the water, splashed and that it is plugged into a GFI GROUND FAULT INTERRUPT OUTLET.
- DO NOT use the device as a bench or table.
- DO NOT place the device directly on structural members.
- A drain pan MUST be placed under the unit if installed above a living area or above an area where water leakage could cause damage

FOR HVAC INSTALLER ONLY

1. Intended Application for Ultra-Aire 150H

For the ideal installation, draw air from the central part of the home and return it to isolated areas of the home like the bedrooms, den, utility room, or family room. The ductwork of the existing heating system can be used to supply air to the home.

2. Specifications

Model:	UA-150H Indoor Air Quality System
Electrical:	110-120 VAC, 12 Amps, 60 Hz, grounded
Capacity:	145 pints/day @ 80°F, 60% RH
Operating Temp. Range:	56°F min., 100°F max.
Air Flow:	400 CFM without external ducting 355 CFM @ .20 IWG external static 290 CFM @ .40 IWG external static
Refrigerant Charge:	2 lb., 2 oz. R-22
Duct connections:	Round 10" & 6" inlets, 10" outlet
Filter Size: Pleated cloth:	2" X 20" X 24" High Efficiency: 4" X 20" X 24"
Size (w/o duct collars):	45 ³ / ₄ " long x 24 ³ / ₄ " wide x 20 ¹ / ₂ " high
Unit Weight:	145 lb., Shipping Weight 229 lb.

3. Installation

3.1 Location

The UA-150H can be installed in a variety of locations to meet the owner's needs as listed below. In all cases keep the following cautions in mind:

- It is designed to be installed INDOORS IN A SPACE THAT IS PROTECTED FROM RAIN AND FLOODING.
- Install the unit with space to access the front panel for maintenance and service. Also allow easy access to the filter cover panel. DO NOT INSTALL UNIT WITH THE FRONT PANEL OR FILTER COVER PANEL INACCESSIBLE.
- Avoid discharging the air directly at people, or over the water in pool areas.
- If used near a pool or spa, be certain there is NO chance the unit could fall into the water or be splashed and that it is plugged into a GROUND FAULT INTERRUPTER.
- DO NOT use the UA-150H as a bench or table.
- DO NOT place the UA-150H directly on structural members.
- A drain pan MUST be placed under the unit if installed above a living area or above an area where water leakage could cause damage.

Place the UA-150H on supports that raise the base of the unit above the top of the flanges on the drain pan beneath it. Raising the UA-150H will help the unit drain with gravity flow. Do not place the UA-150H directly on structural building members without vibration absorbers or unwanted noise may result.

The UA-150H may be suspended with steel hanger straps (plumbers tape) or a suitable alternative from structural members. Remember to place a drain pan under the unit if it is suspended above a finished area or above an area where water leakage could cause damage.

The UA-150H should be located near the existing air handling system to minimize the required ductwork for connecting the UA-150H to the existing air handling system. The controls for the UA-150H are remote from the unit and must be located in the space that is to be conditioned. The controls are low voltage (24 volt) and should be connected to the UA-150H with low voltage thermostat cable.

An external insulation kit is available for the UA-150H. This will prevent the cabinet from sweating if the unit is installed in an unconditioned space. This kit will also increase the efficiency of the unit by eliminating unwanted heat transfer between the unit and the unconditioned space. See the optional parts list for information on the kit.

If fresh air ventilation is desired, thought should be given to the location for the fresh air ducting. A 6" round insulated duct will have to be installed on the UA-150H and run to the outside of the structure to bring in fresh air. Use an 8" insulated round duct for lengths of more than 50 feet or if more than 100 CFM is needed. Consult local codes for necessary distances from exhaust ports when installing fresh air return.

3.2 Electrical Requirements

WARNING: DO NOT ALLOW THE YELLOW LEAD FROM THE ULTRA-AIRE TO CONTACT THE RED LEAD OR ORANGE LEAD FROM THE ULTRA-AIRE OR DAMAGE TO THE TRANSFORMER WILL RESULT.

The UA-150H plugs into a common grounded outlet on a 15 or 20 Amp circuit. It draws around 12 Amps under normal operating conditions. If used in a wet area (pool, spa room, or basement prone to flooding), a ground fault interrupter protected circuit is required.

Install the remote control panel in a central area of the structure where it will sense the relative humidity of the structure accurately. Do not install the control panel where it may not accurately sense the relative humidity such as near HVAC supply registers, near exterior doors, or near a pool or spa. The installer must supply the wiring between the UA-150H and the control panel. Be sure to safely route the control wiring to prevent damage during installation. Be

FOR HVAC INSTALLER ONLY

careful not to cross the wires when connecting the UA-150H and the remote control panel or damage to the transformer may result.

The remote controls of the UA-150H are powered by a low voltage circuit (24 Vac) and must NEVER contact or be connected to a high voltage circuit. The control wires leaving the UA-150H and the remote control panels are numbered and color-coded to prevent confusion. Some of the control wires leaving the UA-150H may not be used with certain control panels and should be left safely disconnected with wire nuts taped onto the stripped ends. Be sure to consult the electrical schematic in this manual or inside the access panel of the UA-150H before making the control connections.

NOTE: RESET THE VENTILATION TIMER BEFORE ATTEMPTING TO PROGRAM AFTER INITIAL INSTALLATION. THE TIMER MAY NOT OPERATE CORRECTLY UNTIL IT IS RESET.

A decorative picture frame is provided to cover the control panel. The home owner may use their choice of picture frames.

If an extension cord is required, it must have a minimum of 12 gauge conductors if 25 feet long or less and 10 gauge conductors if greater than 25 feet long.

3.3 Condensate Removal

Condensate drains by gravity via the clear hose extending from the unit. Route the hose to a suitable drain. Use care to keep the hose as flat to the floor as possible, excessive humps will prevent proper drainage. We do not call for a trap since there is an internal trap with this unit.

If the UA-150H is located too far from a floor drain for the attached hose to reach, inexpensive 1/2" PVC pipe can be used to extend it. It is commonly available in 10' lengths from building supply, plumbing or hardware stores. It will slide tightly inside the end of the drain hose. If more than one length of pipe is required, they can be joined with a short piece cut from the end of the drain hose.

An optional condensate pump kit may be installed if a lift is required to dispose of the condensate. The condensate pump kit can be ordered direct from the factory. See the optional parts list for information on the kit.

3.4 Ducting

3.4A Installing Duct Collars

The UA-150H is equipped with 10" and 6" round inlet collars and a 10" round exhaust collar. The 10" and 6" round inlet collars are designed with tabs that fold inside the filter enclosure of the UA-150H. The 10" round exhaust collar is attached to the UA-150H by folding the tabs inside the end panel of the UA-150H.

To install the collars; Insert the tabs of the collar into the hole in the filter enclosure and/or end panel of the UA-150H and fold the tabs up to attach to UA-150H.

3.4B Ducting for Dehumidification

For the ideal installation, draw air from the central part of the home and return it to the isolated areas of the home like the bedrooms, den, utility room, or family room. The ductwork of the existing heating system can be used to supply air to the home. If the existing supply goes to isolated areas of the home, discharge the supply of the UA-150H into the supply of the existing heating system. If the existing heating system incorporates a central supply, installation of a separate supply duct from the UA-150H to each isolated area is recommended. DO NOT draw air directly from the kitchen, laundry, or isolated basement. You may draw air from a basement that is open to the home. All flexible ducting connected to the UA-150H should be UL listed.

The inlet of the UA-150H is the 10" diameter hole in the filter enclosure of the unit. A 10" round collar is supplied with the unit to attach to round duct. The duct may be permanently attached to the collar. A 6" round collar is provided with the unit to attach to the 6" hole in the filter enclosure. The 6" collar should be capped if fresh make-up air is not desired. If fresh make-up air is desired see section 3.4C.

The outlet of the UA-150H is located on the end of the unit. A second 10" round collar is supplied with the unit. Cut and remove the safety grid, then bend the tabs on the collar inside the hole in the cabinet end.

A length of 6 feet or more of acoustical flex ducting on the outlet of the UA-150H will reduce air noise from the impeller fan. A length of flexible ducting on all UA-150H duct connections is recommended to reduce noise and vibration transmitted to rigid ductwork in the structure.

Ducting the UA-150H as mentioned in sections 3.4A-3.4G requires consideration of the following points:

Duct Sizing: For total duct lengths up to 25', use a minimum 10" diameter round or equivalent rectangular. For longer lengths, use a minimum 12" diameter or equivalent. Grills or diffusers on the duct ends must not excessively restrict airflow.

Isolated Areas: Effective dehumidification may require that ducting be branched to isolated, stagnant areas. Use 8" or larger diameter branch ducting to each of two or three areas, use 6" or larger to each of four or more areas.

Connecting to existing HVAC systems: An optional 10" check damper is available from the factory to prevent reverse flow through the UA-150H. If the UA-150H is ducted to the supply of a high static air handler the check damper may be placed in the UA-150H supply duct. Contact the factory when connecting to a static pressure of greater than or equal to +.5" WG.

3.4C Ducting for Fresh Air

Fresh air can be brought into the structure by connecting a insulated duct from outside to the 6" UA-150H inlet and by turning on the fan switch or activating the humidity control (on units with the humidity control panel). Activate the ventilation timer on units with the ventilating & humidity control panel to bring in fresh air. Refer to section 4.5 for programming instructions for the ventilation timer. Advantages of this form of ventilation include:

1. Outside air is filtered before entering the building.
2. Outside air will be dehumidified before entering if the UA-150H is running in dehumidification mode.
3. Drawing air from outside and blowing inside aids in slightly pressurizing the structure. This helps prevent dirty and humid air from entering elsewhere. It also reduces the potential for carcinogenic radon gas to enter and provides make-up air for open combustion and exhaust devices like the clothes drier, fireplace, and water heater.
4. Adequate exhaust fans are recommended in the bath rooms and kitchen.

In cold climates or areas where the outdoor dew point is low at times, ventilation can be used to dehumidify the structure. This is accomplished by bringing the dry, low dew point air into the structure during these times. This approach is often more economical than running the dehumidifier to remove excess moisture from the structure. In cold climates, it is critical to adequately ventilate to reduce the inside moisture content to avoid moisture accumulating in the wall cavities. For example; in a house that experiences condensation on the interior surface of the windows during the winter, increasing the amount of ventilation will often cure the problem.

An insulated 6" diameter duct is generally sufficient to provide up to 125 CFM of outside air. Large quantities of outside air will impact UA-150H performance positively or negatively, depending upon the inside and outside air conditions. Consult the factory by calling 1-800-533-7533 for recommendations regarding the use of higher flows with your specific application.

The outside air duct should be connected to the 6" round collar on the filter enclosure of the unit. The 6" round collar includes a manual damper. Adjust the manual damper to provide the desired amount of fresh air for ventilation. The amount of fresh air should be based on the size and occupancy of the residence. If you are unsure of your ventilation air requirements, consult the factory by calling 1-800-533-7533 for assistance.

3.4D Installation in a Basement or Crawl Space with an Existing Forced Air HVAC System

If the existing system has multiple returns, select one to disconnect from the existing forced air system and use it for the dedicated UA-150 return. Always select a return from a central location in the structure in an area that is always open to the rest of the structure. Do not use a return from a room that may have its' door closed

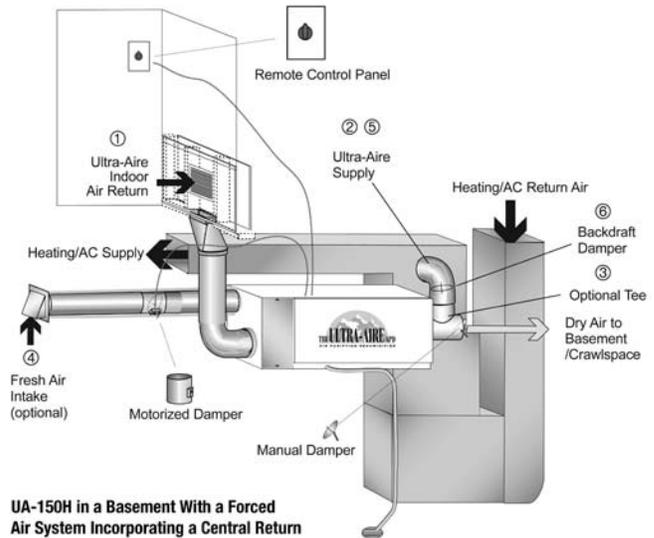

much of the time or install a separate return from the open part of the house.

If the structure in which the UA-150 is to be installed has an existing forced air HVAC system, utilize the HVAC system to make the UA-150 installation easier.

Basement Installation: Install a separate 10" return for the UA-150H in a central area of the structure. Duct the supply of the UA-150 to a 10" x 10" x 10" tee/damper that is 20% open to the basement. Duct the other side of the tee to the air supply of the existing HVAC system. Connect a duct from outside to the 6" collar of the UA-150 if you wish to provide fresh make-up air.

Crawl Space Installation: Install a separate return for the UA-150H in a central area of the structure. Duct the supply of the UA-150H to a 10" x 10" x 10" tee/damper that is 20% open to the crawl space if desired. Duct the other side of the tee to the air supply of the existing HVAC system. Connect an insulated duct from outside to the 6" collar of the UA-150H if you wish to provide optional fresh make-up air.

FOR HVAC INSTALLER ONLY

3.4E Installation in an Attic with an Existing Forced Air HVAC System

ALWAYS install a catch pan with a drain or float interrupt for condensate under the UA-150H in an attic or condensate may drip down on the ceiling of the living space below.

Locate a separate return for the UA-150H in a central area of the structure. Duct the supply of the UA-150H to the air supply of the existing HVAC system. Connect an insulated duct from outside to the 6" collar of the UA-150H if you wish to provide fresh make-up air. Adjust a damper in the duct to provide the desired amount of fresh air.

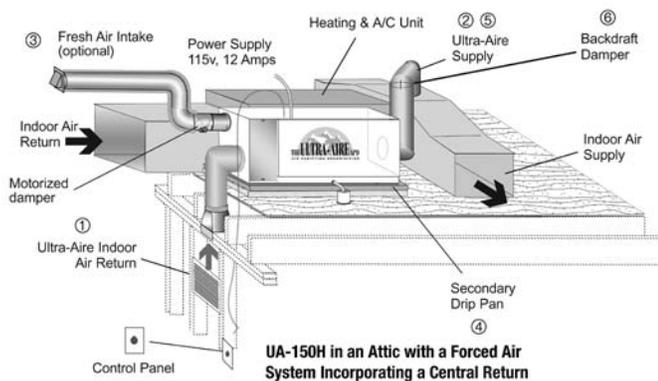

3.4F Installation in a Structure with Two Forced Air HVAC Systems

Attach the UA-150H return to an independent return from the upper level. Attach the UA-150H supply to the supply of the basement HVAC system. This will promote circulation of air through the whole structure from the upper level to the lower level through the UA-150H. If the UA-150H is not connected to both HVAC systems, it will not control the humidity and ventilation of the entire structure. Connect an insulated duct from outside to the 6" collar of the UA-150H if you wish to provide fresh make-up air.

3.4G Installation in a Structure with No Existing Forced Air HVAC System

When installing the UA-150H in a structure that does not have a forced air HVAC system, a single return for the UA-150H should be installed in a central open area of the structure. DO NOT locate the return in a bathroom or a kitchen. The supply of the UA-150H should be located in the remote areas of the structure (such as bedrooms, den, etc.). By ducting this way, the air inside the structure will circulate through the UA-150H to be filtered and dehumidified. 4" diameter duct is recommended for branches to the bedrooms, 6" diameter duct is recommended for branches to larger areas. Refer to section 3.4B for branch duct sizing. Connect an insulated duct from outside to the 6" collar of the UA-150H if you wish to provide fresh make-up air.

3.5 Quiet Installation

The compressor is attached to the cabinet with two cable ties to secure it during shipment. This rigid attachment is not necessary once the unit is installed and may cause noise from compressor vibration. After installation, cut the cable ties to free the compressor from the cabinet.

REMOVE THE HORIZONTAL CABINET SUPPORT TO WHICH THE COMPRESSOR IS ATTACHED. The ends of the support are notched so that the support can easily be removed. Cut the strips of metal on each end and remove the support section from the cabinet. This will prevent the compressor from transmitting vibration to the cabinet.

Make sure none of the compressor tubes are pressed against the cabinet or access panel. Check that the compressor tubes are centered in the holes where they pass through the drain pan.

A length of 10 feet or more of acoustical flex ducting on the outlet of the UA-150H will reduce air noise from the impeller fan. A length of flexible ducting on all UA-150H duct connections is recommended to reduce noise and vibration transmitted to rigid ductwork in the structure.

Install an external insulation kit.

4. Controls

The UA-150H can be equipped with various accessories to enhance its operation. A remote control panel must be used with the UA-150H. There are three remote control from which to choose. The humidity/fan control panel is used to control humidity and the impeller fan. Fresh air is introduced when the impeller fan operates.

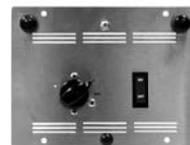

Figure 1:
Humidity/Fan Control Panel
Part No. 4024155



Figure 2: Ventilation Timer
and Humidity Control Panel
Part No. 4024125

The impeller fan operates when dehumidifying or the fan switch is on. The ventilation timer and humidity control panel are used to control humidity, the impeller fan, and preset ventilation schedules. The quantity of fresh air should be 10 ft³/min of fresh air per person plus 1 ft³/min per 100 ft² of floor space.

4.1 Humidity/Fan Control Panel

See Figure 1: The humidity/fan control panel automatically controls the humidity of the living space. The humidity/fan control panel contains an adjustable humidity control and a fan switch. This panel should be mounted in a central area of the structure where it can accurately sense the humidity of the air in the living space. The

FOR HVAC INSTALLER ONLY

panel has a cover that must remain open to the air within the living space for accurate humidity sensing. Position the fan switch on when the home is occupied. The impeller fan blends fresh air with the inside air. It also filters and circulates the blended air throughout the home.

The humidity/fan control panel can be used in conjunction with the optional fresh air damper. When used with the optional fresh air damper, the fan/filter switch will act as a fresh air ventilation control. When the switch is ON (in this configuration), the impeller fan will run, the fresh air damper will open, and fresh air will be filtered and brought into the structure. When the switch is OFF, the fresh air damper will close and the impeller fan will operate only when the humidity control calls for dehumidification. Contact the factory for instructions on this type of installation.

4.2 Ventilation Timer and Humidity Control Panel

See Figure 2: The ventilation timer and humidity control panel automatically controls both the ventilation and the humidity of the living space. The ventilation timer and humidity control panel contains an adjustable humidity control, a fan switch, and a ventilation timer. This panel will control the humidity and allow programmed ventilation of the living space. This panel works in conjunction with the optional fresh air damper to provide ventilation. The minimum fresh air ventilation schedule recommended is “on” when occupied two or more people.

This panel should be mounted in a central area of the structure where it can accurately sense the humidity of the air in the living space. The panel has a cover that must remain open to the air within the living space for accurate humidity sensing.

4.3 Humidity Control Adjustment

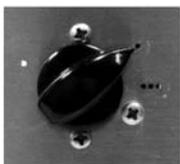

Figure 3:
Humidity Control
Adjustment Knob

Set the humidity control to the desired humidity level for the home. Turning the knob clockwise results in a drier setting. See the back of the control panel cover for set points. The dehumidifier will run continuously until the relative humidity (RH) is reduced to the humidity control dial setting. Setting the humidity control to lower RH levels will NOT increase the unit's dehumidification rate; the unit will simply run

longer to reduce the area's RH to the setting. The UA-150H unit (and refrigerant-based dehumidifiers in general) will reduce a warm space's RH to a lower level than that of a cool space. It is therefore pointless to set the humidity control to excessively low levels in cool rooms; doing so will result in long periods of ineffective dehumidifier run time. Settings below 45% are not recommended.

Quality humidity meters are available from the factory and are recommended to accurately monitor humidity levels.

4.4 Fan/Filter Switch



Figure 4
Fan/Filter Switch

Turning ON the fan/filter switch will cause the the UA-150H impeller fan to run continuously, whether the UA-150H is dehumidifying or not. This function is desirable if the unit is used for air circulation and filtration to achieve maximum indoor air quality. When the switch is ON; air will be constantly filtered through the UA-150H and circulated throughout the house.

When the switch is OFF the impeller fan will operate only when the humidity control calls for dehumidification or when the ventilation timer calls for ventilation.

4.5 Ventilation Timer

The ventilation timer controls the impeller fan and the motorized fresh air damper. When the ventilation timer is activated, the UA-150H will circulate the indoor air, and bring in fresh air from outside. The ventilation timer should be set for the required ventilation of the residence. The home should be ventilated with fresh air as suggested by applicable codes and standards. Minimally, ventilate when occupied by plus two people.

In cold climates or areas where the outdoor dew point is low at times, ventilation can be used to dehumidify the structure. This is accomplished by bringing the dry, low dew point air into the structure during these times. This approach is often more economical than running the dehumidifier to remove excess moisture from the structure. For example; in a house that experiences condensation on the interior surface of the windows during the winter, increasing the amount of ventilation will often cure the problem. To avoid condensation on windows and in walls, increase the ventilation rate and duration immediately. Call the factory for assistance if condensation is not eliminated.

The ventilation timer is an electronic timer that displays the current time. This timer has a battery backup, so it will not require resetting after a power outage. Following a prolonged power outage the display of the timer will flash on and off indicating a power outage has occurred. The one-minute time increments of the ventilation timer allow you to program the ventilation of your home to fit your schedule.

The ventilation timer has six programs with each program having one “on” and one “off” event. A program allows the user to turn the ventilation on at a certain day and time, then it allows them to turn the ventilation off at a certain day and time. Each of these programs can be repeated daily or weekly or during a specified block of days. All six of the programs operate independently of each other.

FOR HVAC INSTALLER ONLY

If the timer fails to operate or operates erratically, check that the control panel receives 24Vac from the UA-150H. If 24Vac is present at the control panel, reset the timer by pressing the reset button at the bottom center of the timer face. The reset button is the small recessed button with an R beneath it located below the 1...7 and h buttons. Press the reset button in until the display clears. Release the reset button. The display will reappear as 00:00. Resetting the timer will clear the time and all program settings. After resetting the timer follow the instructions below to set the correct time and ventilation programs.

Setting The Time: The following instructions explain how to set the ventilation timer. First, set the correct time on the timer by sliding the switch in the upper right hand corner of the timer to the clock symbol • and pressing the 1...7 (DAY), h (HOUR), and m (MINUTE) buttons. Remember that this timer operates on a 24-hour (military time) clock.

Ventilation Schedule: Slide the switch in the upper right hand corner to the program symbol P. "ON" will appear to the right of the time and the number "1" will appear in the lower right hand corner of the display. The "1" and "ON" signify the turn on time for the first program. Press the 1...7 button to choose the days of the week for this program. You can choose Mon.-Sun, Mon.-Fri., Sat-Sun, or any single day of the week. The days chosen are shown along the top of the display on the ventilation timer. Next press the h button to set the hour for the start of the ventilation period. Remember that this timer operates on a 24-hour clock. Then press the m button to set the minutes past the hour to start the ventilation. Now, with the ventilation start time set; press the I/O button. The word "OFF" should appear to the right of the time and the number "1" should remain in the lower right hand corner of the display. The "1" and "OFF" signify the turn off time for the first program. Set the turn off time using the 1...7, h, and m buttons in the same way as described above and continue on to the second through sixth programs. When setting the ventilation programs, you can return to the current time display by sliding the switch in the upper right corner of the timer to RUN. The slide switch in the upper right must be set to RUN for the timer to operate with the scheduled programs.

Automatic or Manual Mode: The slide switch in the upper left of the timer is used to choose between automatic and manual operation of the timer relay. When the slide switch in the upper left of the timer is set to AUTO mode, the UA-150H will ventilate when the scheduled programs call for ventilation. When the slide switch in the upper left of the timer is set to manual (set to hand symbol on the right), the operation of the timer is controlled by the I/O button only. Pressing the I/O button will switch the ventilation timer between ON (detent) and OFF (detent). As you press the I/O button, "ON" or "OFF" will be displayed to the right of the time. The "ON" or "OFF" to the right of the time will indicate if the ventilation timer is on or off. The I/O button will manually override scheduled programs if the timer is in AUTO mode.

4.6 Low Pressure Control

If the low side refrigerant pressure drops to 15 PSIG, the low-pressure control opens and shuts off the compressor and impeller fan. It is an automatically reset control that will close when the pressure rises to 35 PSIG. Its primary function is to prevent damage to the compressor if a leak develops in the refrigeration system. It may also open if the unit is A) installed in a cool area (below 50 F) or B) installed where it is below 40 F and then started. Under these conditions, the unit will restart within several minutes. Until the unit warms up, it may repeat the cycle several times.

ATTENTION INSTALLER

WIRE THE UNIT AND CONTROL PACKAGE AS SHOWN IN THE DIAGRAM BELOW

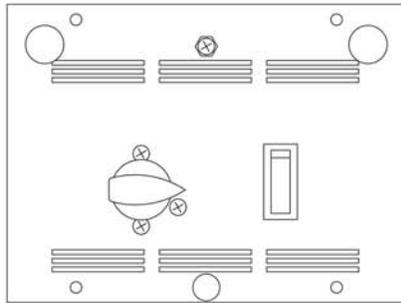

CONTROL PART No. 4024155

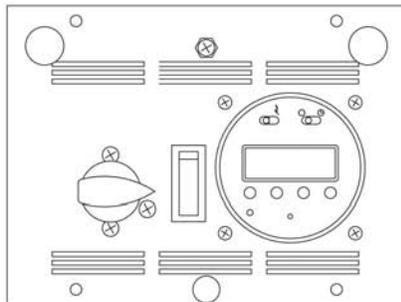
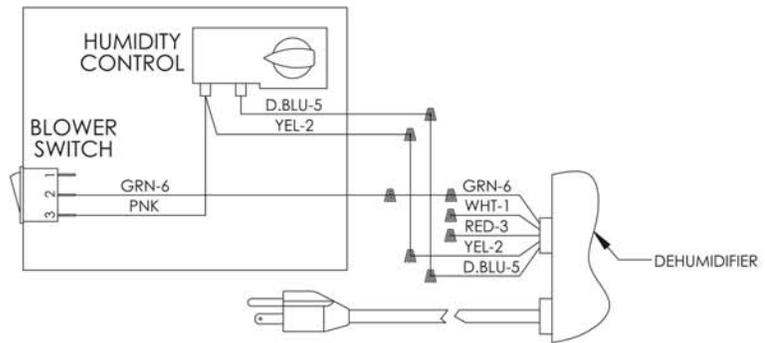

CONTROL PART No. 4024125

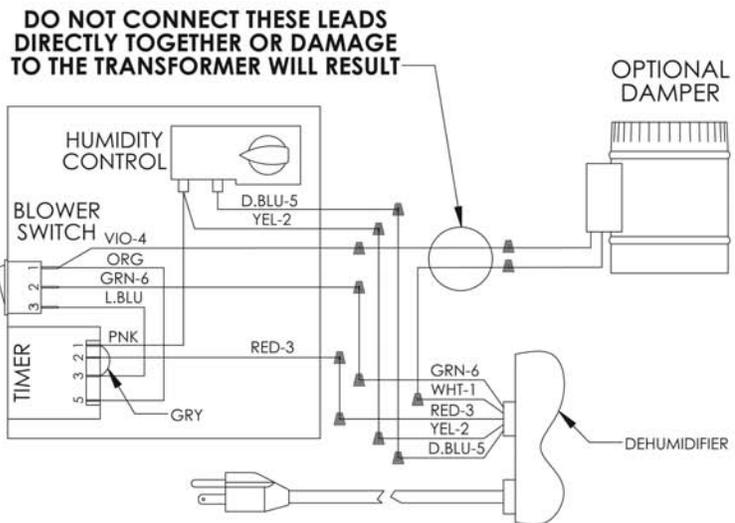

CONTROL PART No. 4024539

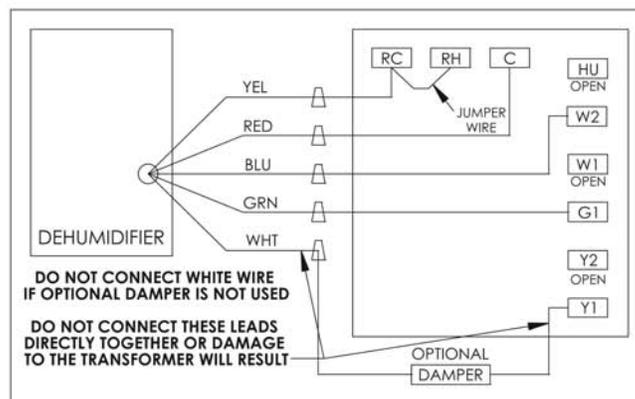

WARNING: DO NOT allow the yellow lead from the unit to contact the red lead or the white lead from the unit or damage to the transformers will result. Do not direct connect the white lead on the unit to the violet lead on the ventilation control or damage to the transformer will result.

5. (DEH 2000) DIGITAL CONTROL Installation Instructions



Figure 5: DEH 2000 User Panel

- On/Off
- Program
- Clock
- Fan
- Damper
- F/C
- Humidity

5.1 Specifications

Model: 4024539
 Electrical: 24 VAC
 Humidity Range: 20 – 90%
 RH Humidity Accuracy: +/- 4%
 Output: 3 Amps 24 VAC

5.2 Installation

This control panel must be installed in the conditioned space and in accordance with all applicable codes and standards. Follow the instructions below when installing and setting this control.

5.2A Install Instructions

1. Separate the front panel from the back panel by depressing the tongue located in the bottom of the control.



Figure 6: Release tongue.

2. Gently disconnect the quick connector on the back panel
3. Remove the battery from the back panel by sliding it to the left and out from its retaining clip. To mount in the black battery holder on the front panel, insert it from the top, gently pressing downward until it snaps into place and is held under the top clip of the holder. The + engraved on the battery should be visible.
4. Line the back panel up against the wall or flat surface onto which it is to be mounted and drill in the appropriate mounting holes
5. Insert the screws so they extend approximately 1/8" from the wall or flat surface.

6. Align the back panel against these screws, pushing it forward, allowing it to slide downward to lock into position.
7. Make the electrical connections to the terminals on the back panel as shown in the wiring diagram.
8. Seal the hole around the wires to prevent air movement.
9. Reconnect the quick connector onto the back panel.
10. Reassemble the front to the back panel. Connect at the top first, then at the bottom.

5.2B Wiring

! WARNING

Warning: Do not allow the yellow lead from the Ultra-Aire to contact the red lead or orange lead from the Ultra-Aire or damage to the transformer will result.

The installer must supply the wiring between the Ultra-Aire and the control panel. Be sure to safely route the control wires to prevent damage during installation. Be careful not to cross wires when connecting the Ultra-Aire and the remote control panel or damage to the transformer may result.

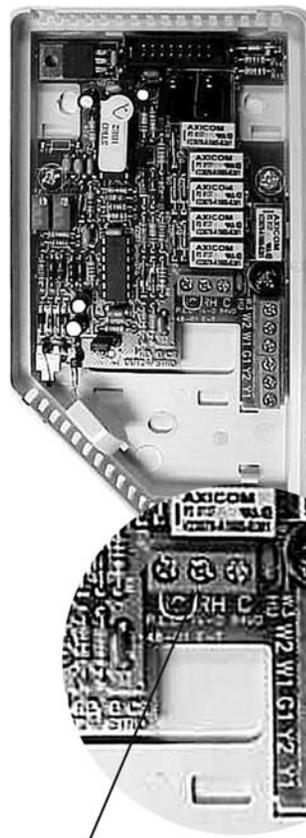

! IMPORTANT

The remote controls of the Ultra-Aire are powered by a low voltage circuit (24 VAC) and must NEVER contact or be connected to a high voltage circuit.

Some of the control wires may not be used with certain control panels and should be left safely disconnected with wire nuts taped onto the stripped ends. Be sure to consult the electrical schematic in this manual before making the control connections.

Figure 7: Wiring the DEH 2000 control.

RC - 24 VAC Yellow Wire	RC - 24 VAC Yellow Wire	HU - Not Used	G1 - Fan Green Wire
RH - Not Used	RH - Not Used	W2 - Dehumidistat	Y2 - Not Used
C - 24 VAC Red Wire	C - 24 VAC Red Wire	Dark Blue Wire	Y1 - Damper (See Warning Next Page) White Wire
		W1 - Not Used	

! IMPORTANT Leave Jumper Wire RC and RH in place.

FOR HVAC INSTALLER AND HOMEOWNER

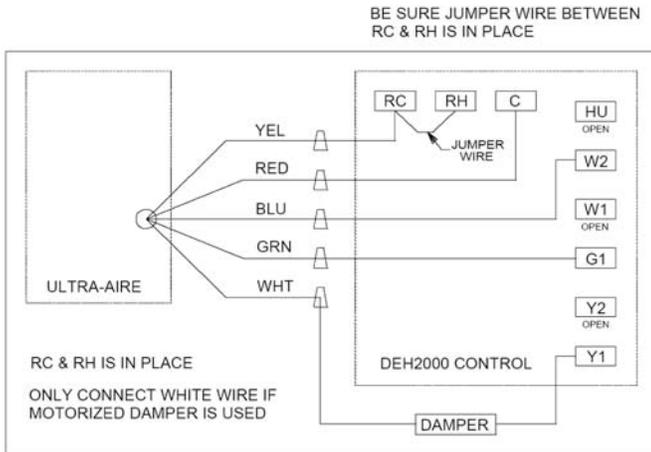

Figure 8: DEH 2000 Wiring Diagram

! WARNING

Warning: Connecting the white wire to the control terminal without use of a motorized damper could create a short resulting in damage to the transformer.

The white wire controls the motorized damper that can be installed into a fresh air duct. This provides the ability to control when fresh air is introduced into the building by using the ventilation timer function labeled “damper” on the control. If the motorized damper is not used, **DO NOT CONNECT THE WHITE WIRE TO THE CONTROL OR DAMAGE TO THE TRANSFORMER MAY RESULT.** Simply leave the white wire terminal (Y1) unused if the damper is not used.

5.2C Location

Install the remote control panel in a central area of the structure where it will sense the relative humidity of the structure accurately. Do not install the control panel where it may not accurately sense the relative humidity such as near HVAC supply registers, near exterior doors and windows, or near a pool or spa.

5.3 Operation

5.3A Display

When there is power to the control, the control display sequence will alternately show the clock, humidity, temperature, fan status, and fresh air damper status. The display sequence repeats continually, and is referred to as “home state”.

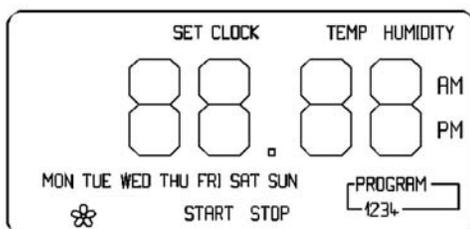

Figure 9: DEH 2000 digital display.

- The word “CLOCK” appears at the top of the display during the clock display, along with the day and time.
- The word “HUMIDITY” appears during the humidity display, with the current Set point on the left, and the ambient RH on the right.
- The word “TEMP” appears as the unit displays the current temperature.
- The fan status display is indicated by a capitol “F”. “OF” indicates fan off status, “on” indicates fan on status.
- The damper display is indicated by a “d” with the same on/off status indicators as the temperature.
- The ventilation program is displayed along the bottom of the display during the clock, humidity, and temperature displays only when the damper operation is set to the programmed setting “Pr”.

5.3B Setting

During the set-up process, if you make a mistake, you can always go back to adjust the settings. If you leave the control alone and don’t touch any buttons for 10 seconds, the control will remember any changes made and return to “home state.”

5.3C On/Off Setting

Press the “ON/OFF” button to turn the system on or off. When the system is on, the green indicator will be lit. In the off mode, the controller continues the regular display sequence and indicates current time, temperature, and relative humidity. It also displays the status of the fan and damper as if the control were on, but the fan and damper will not operate unless the control is on and the green indicator is lit. Setup can be done with the control either on or off.

5.3D Setting Clock Time

1. Push “CLOCK” button. The hour display will flash, use the “SET” + or – button to adjust hour. Notice the a.m./p.m. display.
2. Push “CLOCK” button again. The minute display will flash. Use the “+,-” buttons to adjust to the proper time.
3. Push “CLOCK” button again. The day display will flash. Use the “+,-” buttons to select the proper day.
4. Push “CLOCK” button again. The AM/PM display will flash. Verify AM/PM setting is correct.
5. Push “CLOCK” button again, or wait a few seconds for the display to stop flashing. The time is now set.



Figure 10: Setting clock time.

5.3E Setting Relative Humidity Set point

The relative humidity Set point operates the dehumidifier function of the Ultra-Aire. It has no effect on any other function of the unit. The control senses the ambient relative humidity of the space in which it is located. The ambient condition is displayed on the right in the relative humidity display sequence, under the word "HUMIDITY". The current Set point is displayed on the left, under the word "SET".

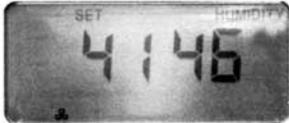

Figure 11: Setting relative humidity Set point.

If the Set point is equal to or greater than the current ambient condition, the space does not need to be dried, so the dehumidifier function will be off. Example: Set point: 50%RH Current condition 45% RH = Dehumidifier off, red "DEHU" indicator not lit.

If the Set point is less than the ambient condition, the dehumidifier will be on, and the red "DEHU" indicator will be lit. The space is more humid than the Set point, so the controller operates the dehumidifier to dry the space. Example: Set point: 50% RH Current condition: 55% RH = Dehumidifier on, red "DEHU" indicator lit.

To set the relative humidity Set point, press the "HUM" button. The display will show the "HUMIDITY" display, and the word "SET" will flash. Use the "SET" + or – buttons to adjust the relative humidity Set point as desired. Therma-Stor LLC recommends relative humidity levels of 45% in the summer, and lower levels in the winter. It is not recommended the humidity Set point be set below 35%. In order to dry the home in the winter in a cold climate, use the ventilation function of the system rather than the dehumidifier function.

5.3F Fan Setting and Operation

Use the "FAN" button to adjust the fan operation. There are 3 choices for fan operation: "on", "off" (denoted by "OF"), or program (denoted by "Pr"). To set operation,

1. Press the "FAN" button. The display will indicate the current fan setting.
2. Use the "SET" + or – buttons to adjust fan operation ("on", "OF" or "Pr"). Press the "FAN" button again or leave the unit alone for 10 seconds to return to home state.



Figure 12: Programming the fan.

5.3G Fan On Fan Off Fan Program

The fan display reading in the normal display sequence does not indicate the current fan setting, it indicates the current fan status, and will always read either on or off. With the fan in the

"on" mode, the fan will run continuously. This does not effect the dehumidification functions of the system. The system may or may not be ventilating or dehumidifying while the fan is running. Common reasons for operating the fan continuously are continuous filtration and air recirculation. With the fan in the "off" or "program" mode, the fan will operate only when needed by other functions of the system. The fan will remain off unless the system is dehumidifying and/or ventilating. The fan always runs during dehumidification, it also always runs during ventilation. To completely turn the system off, use the "ON/OFF" button as described earlier.

5.3H Damper Operation and Setting (Ventilation)

The damper setting controls the ventilation function of the system. It has no control over the dehumidification function. In order to provide ventilation, the damper must be open ("on") and the fan must be running. The controller takes care of these two functions automatically, so whenever the damper is open ("on"), the fan is running.

This is true even if the fan has been set to the "off" mode. The ventilation indicator will be lit whenever the unit is ventilating.

There are three damper operation modes, "on", "off" (denoted by "OF"), and program (denoted by "Pr"). With the damper in the "on" mode, the damper will be open and the fan of the system will be operating in order to introduce fresh air into the space. Use this mode for continuous fresh air ventilation. The fan is always on when the damper is open. When in "off" mode, the damper will not open and the system will not ventilate.

When in the "program" mode, the control will operate the damper and fan (ventilate) according to the programmed ventilation schedule (see the section referring to programming the ventilation schedule).

To select damper operation:

1. Press the "DAMPER" button. The letter "d" will appear on the display, along with the current mode setting.
2. Use the "SET" + or – buttons to adjust the fan setting to the desired mode ("on", "OF", or "Pr").
3. Press the "DAMPER" button again or leave the control alone for 10 seconds to select the indicated damper mode and return to the home state.



Damper On

Damper Off

Damper Program

Figure 13: Damper operation and setting.

FOR HVAC INSTALLER ONLY AND HOMEOWNER

6.3I Intermittent or Programmed Ventilation

With the damper in program mode (denoted by “Pr” when setting the damper operation) the system will operate the ventilation function according to the current ventilation program.

There are 4 programs available for ventilation Monday through Friday. There are also 4 programs for Saturday and 4 programs for Sunday. No other choice of days is available. Each program to be used has an “on event” called “START” which brings the ventilation function on, and an “off event” called “STOP” which turns the function off. Each START and STOP must be entered in to the controller.



Figure 14: Programmed ventilation.

To set or adjust the ventilation program:

1. Press the “PROG” button two times. The display will indicate “Program 1/start” at the bottom, and the hour display will flash.
2. Use the “SET” + or – button to adjust the hour for the Program 1 start time. Be sure to pay attention to the am/pm setting.
3. Press the “PROG” button again. The display will indicate “Program 1/start” at the bottom, and now the minute display will flash.
4. Use the “SET” + or – buttons to adjust to the desired minute setting.
5. Press the “PROG” button again to move on to the “Program 1/stop” event. The display will indicate “Program 1/stop” at the bottom, and the hour display will flash.
6. Use the “SET” + or – button to adjust the hour for the Program 1 stop time. Be sure to pay attention to the am/pm setting.
7. Press the “PROG” button again. The display will indicate “Program 1/stop” at the bottom, and now the minute display will flash.
8. Use the “SET” + or – buttons to adjust to the desired minute setting.

9. Pressing the “PROG” button again to move onto “program 2/stop” and begin the process again if setting the other programs. Follow the same procedure for each program.

10. To end the program process simply leave the control alone (don’t push any buttons) for about 10 seconds. The unit will remember any changes and return to “home state”.

5.3J Programming Notes

To run the ventilation program, the damper mode must be in the “program” mode (“Pr”).

The timer can be operated manually without changing the program by adjusting the damper mode from “program” to either “on” or “off”.

To delete a program after it has been entered, adjust the program so the “START” and “STOP” times are identical.

Occupants should determine ventilation times and rates. Therma-Stor LLC makes no firm recommendations concerning when to ventilate. Common ventilation schedules include constant ventilation, ventilation based on occupancy times, intermittent operation, and seasonal ventilation.

Remember the control must be on for the unit to be functioning - make sure the green power indicator “ON” is lit.

5.3K Ventilating or Dehumidifying to Control Indoor Relative Humidity Levels

Fresh air ventilation may have a drying effect or a wetting effect on the indoor space, depending on the amount of moisture present in the outdoor air. Relative humidity is not a good indicator of outside humidity levels: use dew point measurements instead. Consider outside humidity levels when using the ventilation function of the dehumidifier.

5.3L Stop Start

During summer in hot, humid climates operating in ventilation mode will increase the moisture load in the home.

Consider reducing the amount or frequency of fresh air ventilation if indoor humidity continues to be high.

5.3M Low Pressure Control

If the low side refrigerant pressure drops to 15 PSIG, the low-pressure control opens and shuts off the compressor and impeller fan. It is an automatically reset control. It will close when the refrigerant pressure rises to 35 PSIG. Its primary function is to prevent damage to the compressor if a leak develops in the refrigeration system. It may also open if the unit is A) installed in a cool area (below 50 F) or B) installed where it is below 40 F and then started. Under these conditions, the unit will restart within several minutes. Until the unit warms up, it may cycle several times.

6. Maintenance

6.1 Standard Air Filter

The UA-150H is equipped with a pleated cloth air filter. This filter should be checked every three months. Operating the unit with a dirty filter will reduce dehumidifier capacity and efficiency and may cause the compressor to cycle off and on unnecessarily on the defrost control.

To access the air filter, remove the filter access panel from the end of the UA-150H by unscrewing the two thumbscrews and sliding the panel to the left until it is free from underneath the side panel. The filter(s) should be readily visible and can be removed by pulling them straight out of the UA-150H.

The pleated cloth filter can generally be vacuumed clean several times before needing replacement. Replacement filters can be ordered from the factory or purchased locally if available. DO NOT operate the unit without the standard filter or with a less effective filter than the standard filter. The heat exchange coils inside the unit could become clogged and require disassembly to clean.

6.2 High Efficiency Air Filter

An optional high efficiency pleated microglass paper filter is available for the UA-150H. This filter is rated as 90%-95% efficient by the ASHRAE Dust Spot test method 52-76. The high efficiency pleated microglass paper filter should be used in conjunction with the standard filter, and placed directly behind the standard filter.

This filter is able to remove allergy-causing particles from the airstream. Check the high efficiency air filter every two years and replace if necessary. The high efficiency filter has a much larger surface area than the standard filter, thus the standard filter may need to be cleaned or replaced several times before the high efficiency filter requires replacement. Be careful not to damage the fabric media when handling the high efficiency pleated paper filter. Do not attempt to clean the high efficiency pleated paper filter. It should be replaced when it becomes restrictive (See Figure 7).

6.3 Impeller Fan Oiling

The impeller fan motor is factory lubricated for many years of normal operation, and no further oiling is required.

6.4 Optional Fresh Air Return

Check and clean the screen on the outdoor fresh air return seasonally. The screen may become plugged during the seasons when there are many particles in the outdoor air.

7. Service

7.1 Warranty

A warranty certificate has been enclosed with this unit; read it before any repair is initiated. If a warranty repair is required, call the factory first at 1-800-533-7533 for warranty claim authorization and technical assistance.

7.2 Technical Description

The UA-150H uses a refrigeration system similar to an air conditioner's to remove heat and moisture from incoming air, and add heat to the air that is discharged (See Figure 15).

Hot, high-pressure refrigerant gas is routed from the compressor to the condenser coil (See Figure 3). The refrigerant is cooled and condensed by giving up its heat to the air that is about to be discharged from the unit. The refrigerant liquid then passes through a filter/drier and capillary tubing which causes the refrigerant pressure and temperature to drop. It next enters the evaporator coil where it absorbs heat from the incoming air and evaporates. The evaporator operates in a flooded condition, which means that all the evaporator tubes contain liquid refrigerant during normal operation. A flooded evaporator should maintain nearly constant pressure and temperature across the entire coil, from inlet to outlet.

The mixture of gas and liquid refrigerant enter the accumulator after leaving the evaporator coil. The accumulator prevents any liquid refrigerant from reaching the compressor. The compressor evacuates the cool refrigerant gas from the accumulator and compresses it to a high pressure and temperature to repeat the process.

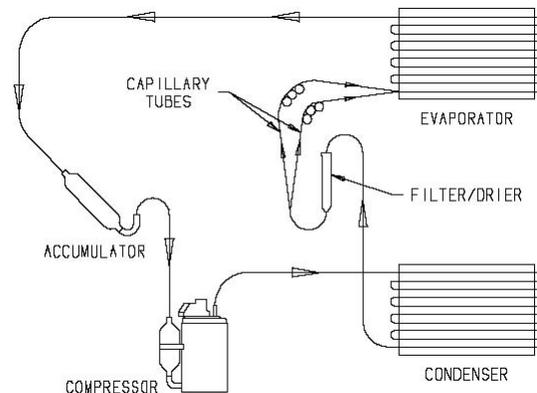

Figure 15: Refrigeration System of UA-150H

7.3 Troubleshooting

No dehumidification, neither impeller fan nor compressor run with fan switch and ventilation timer OFF.

1. Unit unplugged or no power to outlet.
2. Humidity control set too high or defective (Sec. 3.3 & 5.7A)
3. Loose connection in internal or control wiring.
4. Defective Compressor relay.
5. Defective control transformer.
6. Low pressure Control open (Sec 3.7 & 5.10).
7. Optional Condensate Pump Safety Switch open (Sec 5.11).

No dehumidification, compressor does not run but impeller fan runs with fan switch and ventilation timer OFF and humidity control turned to ON.

1. Defective compressor run capacitor (Sec. 5.6).
2. Bad connection in compressor circuit (See Fig. 4).
3. Defective compressor overload (Sec. 5.6A).
4. Defective compressor (Sec. 5.6).
5. Defrost thermostat open (Sec. 5.8).

Impeller fan runs with fan switch and ventilation timer OFF, but compressor cycles on & off.

1. Low ambient temperature and/or humidity causing unit to cycle through defrost mode.
2. Defective compressor overload (Sec. 5.6A).
3. Defective compressor (Sec. 5.6).
4. Defrost thermostat defective (Sec. 5.8).
5. Dirty air filter(s) or airflow restricted.
6. Low refrigerant charge, causing defrost control to cycle.
7. Bad connection in compressor circuit.

Impeller fan does not run with fan switch in either position. Impeller fan does not run with ventilation timer activated. Compressor runs briefly but cycles on & off with humidity control turned to ON.

1. Loose connection in impeller fan circuit (See Fig. 4).
2. Obstruction prevents impeller fan rotation.
3. Defective impeller fan.
4. Defective impeller fan relay.
5. Defective impeller fan capacitor.

Impeller fan runs with fan switch ON. Impeller fan does not run with ventilation timer activated.

1. Defective ventilation timer.
2. Time not correct on ventilation timer.
3. Ventilation timer set to manual & switched OFF.
4. Defective fan switch.

Evaporator coil frosted continuously, low dehumidifying capacity.

1. Defrost thermostat loose or defective (Sec. 5.8).
2. Low refrigerant charge
3. Dirty air filter(s) or airflow restricted.
4. Excessively restrictive ducting connected to unit.

Unit not providing ventilation. Ventilation timer not operating correctly.

1. If timer is not functioning correctly reset timer and reprogram (Sec. 3.5).
2. Check control wire connections (check connections at fresh air damper also).
3. Defective fresh air damper (Sec. 5.9).
4. Defective fan switch.

Unit removes some water, but not as much as expected.

1. Air temperature and/or humidity have dropped.
2. Humidity meter and or thermometer used are out of calibration.
3. Unit has entered defrost cycle (Sec. 5.8).
4. Air filter dirty (Sec. 4.1 & 4.2).
5. Defective defrost thermostat (Sec 5.8).
6. Low refrigerant charge (Sec. 5.4).
7. Air leak such as loose cover or ducting leaks.
8. Defective compressor (Sec. 5.6).
9. Restrictive ducting (Sec. 2.4).
10. Optional Condensate Pump Safety Switch open (Sec 5.11).

Unit Test to determine problem:

1. Detach field control wiring connections from main unit.
2. Connect the yellow and green pigtailed from the main unit together; only the impeller fan should run. Disconnect the wires.
3. Connect the yellow and blue pigtailed from the main unit together; the compressor and impeller fan should run.
4. If these tests work, the main unit is working properly. You should check the control panel and field control wiring for problems next.
5. Remove the control panel from the mounting box and detach it from the field installed control wiring. Connect the blue, yellow, and green wires from the control panel directly to the corresponding colored pigtailed on the main unit. Leave the violet, white and red wires disconnected!
6. Turn on the fan switch; the impeller fan should run. Turn off the fan switch.
7. Turn on the humidity control; the compressor and impeller fan should run.
8. If these tests work, the problem is most likely in the field control wiring.

FOR HVAC INSTALLER ONLY

7.4 Refrigerant Charging

If the refrigerant charge is lost due to service or a leak, a new charge must be accurately weighed in. If any of the old charge is left in the system, it must be recovered before weighing in the new charge. Refer to the unit nameplate for the correct charge weight and refrigerant type.

7.5 Impeller Fan Replacement

The motorized impeller fan is a unitary assembly consisting of the motor and impeller fan. If defective, the complete assembly must be replaced.

1. Unplug the power cord.
2. Remove the cabinet access panel.
3. Remove the screw attaching the impeller fan support bracket to the base.
4. Disconnect the impeller fan leads inside the electric box.
5. Push up on the inlet ring and pull the impeller fan and impeller fan support bracket to the right.
6. Align the bracket with the two notches in the front flange of the base (behind the foam).
7. Slide the impeller fan assembly from the unit.
8. Remove the defective impeller fan from the bracket and replace with it with the new impeller fan.
9. Reassemble the new impeller fan by reversing the above procedure. Note: There are two pins on the backside of the cabinet that must align with the two holes in the impeller fan support bracket.

7.6 Compressor/Capacitor Replacement

This compressor is equipped with a two terminal external overload and a run capacitor, but no start capacitor or relay (See Figure 4).

7.6A Checking Compressor Motor Circuits

Perform the following tests if the impeller fan runs but the compressor does not with the fan switch and ventilation timer OFF and the humidity control ON.

1. Unplug the unit; remove the cabinet side and the electrical connection cover on the compressor top.
2. Plug in the unit and turn the humidity control to ON. Check for 110 volts from compressor terminal R to overload terminal 3 using an AC voltmeter. If voltage is present, go to step 3. If no voltage, there may be a loose connection in the compressor circuit. Test each component for continuity. See the appropriate section if a defect is suspected.
3. Unplug the unit, and then disconnect the red and yellow wires from compressor terminals R & S. Using an ohmmeter check continuity between the points listed below.
4. Compressor terminals C and S: No continuity indicates an open start winding. The compressor must be replaced. Normal start winding resistance is 3 to 7 ohms.

5. Compressor terminals C and R: No continuity indicates an open run winding. The compressor must be replaced. Normal run winding resistance is .5 to 2 ohms.
6. Compressor terminal C and overload terminal 1: No continuity indicates a defective overload lead.
7. Overload terminals 1 and 3: If there is no continuity, the overload may be tripped. Wait 10 minutes and try again. If there is still no continuity, it is defective and must be replaced.
8. Compressor terminal C and compressor case: Continuity indicates a grounded motor. The compressor must be replaced.
9. Disconnect the wires from the run capacitor. Set the ohmmeter to the Rx1 scale. The capacitor is shorted and must be replaced if continuity exists across its terminals. If there is no needle movement with the meter set on the Rx100000 scale, the capacitor is open and must be replaced.
10. Reconnect the wires to the compressor and capacitor. Plug in and turn on the unit. If the compressor fails to start, replace the run capacitor.
11. If the unit still does not start, adding a hard-start kit (relay & capacitor) will provide greater starting torque. If this doesn't work, the compressor has an internal mechanical defect and must be replaced.

7.6B Replacing a Burned Out Compressor

The refrigerant and oil mixture in a compressor is chemically very stable under normal operating conditions. However, when an electrical short occurs in the compressor motor, the resulting high temperature arc causes a portion of the refrigerant oil mixture to break down into carbonaceous sludge, a very corrosive acid, and water. These contaminants must be carefully removed otherwise even small residues will attack replacement compressor motors and cause failures.

The following procedure is effective only if the system is monitored after replacing the compressor to insure that the clean up was complete.

1. This procedure assumes that the previously listed compressor motor circuit tests revealed a shorted or open winding.
2. Remove and properly dispose of the system charge. DO NOT vent the refrigerant or allow it to contact your eyes or skin.
3. Remove the burned out compressor. Use rubber gloves if there is any possibility of contacting the oil or sludge.
4. To facilitate subsequent steps, determine the type of burn out that occurred. If the discharge line shows no evidence of sludge and the suction line is also clean or perhaps has some light carbon deposits, the burn out occurred while the compressor was not rotating. Contaminants are therefore largely confined to the compressor housing. A single installation of liquid and suction line filter/driers will probably clean up the system.

FOR HVAC INSTALLER ONLY

If sludge is evident in the discharge line, it will likely be found in the suction line. This indicates the compressor burned out while running. Sludge and acid have been pumped throughout the system. Several changes of the liquid and suction filter/driers will probably be necessary to cleanse the system.

5. Correct the system fault that caused the burn out. Consult the factory for advice.
6. Install the replacement compressor with a new capacitor and an oversized liquid line filter.

In a running burn out, install an oversized suction line filter/drier between the accumulator and compressor. Thoroughly flush the accumulator with refrigerant to remove all trapped sludge and to prevent the oil hole from becoming plugged. A standing burn out does not require a suction line filter/drier.

7. Evacuate the system with a good vacuum pump and accurate vacuum gauge. Leave the pump on the system for at least an hour.
8. Operate the system for a short period of time, monitoring the suction pressure to determine that the suction filter is not becoming plugged. Replace the suction filter/drier if pressure drop occurs. If a severe running burn out has occurred, several filter/driers may have to be replaced to remove all of the acid and moisture.

NOTE: NEVER use the compressor to evacuate the system or any part of it.

7.6C Replacing a Compressor, Nonburn Out

Remove the refrigerant from the system. Replace the compressor and liquid line filter/drier. Charge the system to 50 PSIG and check for leaks. Remove the charge and weigh in the refrigerant quantity listed on the nameplate. Operate the system to verify performance.

7.7 Remote Controls

The UA-150H is controlled by devices mounted on a panel that is remote from the unit. You may or may not have the devices listed below depending on the model of the remote control panel you purchased. If the UA-150H fails to operate as desired, always check the settings of the controls to insure that they are correct. Check that the controls are receiving 24Vac from the UA-150H. Check the connections between the UA-150H, the control panel, and the field control wiring.

7.7A Humidity Control

The humidity control is an adjustable switch that closes when the relative humidity of the air in which it is located rises to the dial set point. It opens when the RH drops 4 to 6% below the set point. If the UA-150H does not run, try turning the humidity control clockwise until it reaches the stop and the knob pointer points at "Max Dry"

(see back of control panel cover). If it still does not run, remove the stop screw from the panel and turn the knob farther. If it then runs, the humidity control is out of calibration or the RH is below 40%.

The UA-150H is equipped with an automatic defrost mechanism. If the UA-150H operates in conditions that develop frost on the evaporator, it will sense the frost build-up and automatically defrost the evaporator. The UA-150H may not appear to be operating correctly during the defrost sequence, but once the defrost sequence is completed, the UA-150H will resume dehumidifying.

7.7B Programmable Ventilation Timer

The ventilation timer controls the impeller fan and the motorized fresh air damper. When the ventilation timer is activated, the UA-150H will circulate the indoor air, and bring in fresh air from outside. The ventilation timer should be set for the required ventilation of the residence. The home should be ventilated with fresh air as suggested by applicable codes and standards.

If the UA-150H fails to ventilate as expected, check that the time on the timer is correct. For the timer to carry out the program schedule, the slide switch in the upper left corner on the timer must be set to "AUTO". The slide switch in the upper right corner of the UA-150H must be set to "RUN". Also check the programs on the timer to be sure that the timer is calling for ventilation at the correct times. If the timer fails to operate or operates erratically, reset the timer; see section 4.5 of this manual.

7.8 Defrost Thermostat

The defrost thermostat is attached to the refrigerant suction tube between the accumulator and the compressor. It will automatically shut the compressor off if the low side refrigerant temperature drops due to excessive frost formation on the evaporator coil. The impeller fan will continue to run, causing air to flow through the evaporator coil and melt the ice. When the ice has melted, the evaporator temperature will rise and the thermostat will restart the compressor.

7.9 Electric Ventilation Damper

The electric ventilation damper is controlled by the ventilation timer. The damper will open when the ventilation timer is activated to allow fresh air into the structure through the 6" diameter fresh air inlet duct. The electric ventilation damper will remain closed when the ventilation timer is not activated to prevent over-ventilating the structure when the unit is dehumidifying or recirculating the indoor air.

The electric ventilation timer operates on 24 Vac from the control circuit. DO NOT connect high voltage to the damper motor or damage to the motor may result. DO NOT force the blade of the damper by hand or damage to the damper motor may result.

The damper opens in one direction only. The damper rotates very slowly, allow sufficient time for the damper to cycle. The damper will take approximately 1 minute to cycle from closed to open or from open to closed.

FOR HVAC INSTALLER ONLY

If the electric ventilation damper fails to operate:

1. Check that the wiring is correct and that voltage is present at the damper motor.
2. Check for any obstruction inside the damper. If the electric ventilation damper fails to operate after performing these checks, it must be replaced.

7.10 Low Pressure Control

If the low side refrigerant pressure drops to 15 PSIG, the low-pressure control opens and shuts off the compressor and impeller fan. It is an automatically reset control. It will close when the refrigerant pressure rises to 35 PSIG. Its primary function is to prevent damage to the compressor if a leak develops in the refrigeration system. It may also open if the unit is A) installed in a cool area (below 50 F) or B) installed where it is below 40 F and then started. Under these conditions, the unit will restart within several minutes. Until the unit warms up, it may cycle several times.

7.11 Condensate Pump Kit

An optional condensate pump kit is available from the factory for use with the UA-150H. Condensate is automatically pumped to a remote location when the water level in the pump's reservoir rises to close the float switch.

The pump also contains a safety float switch. The white leads from this switch extend from beneath the pump cover. This switch should be installed in series with the field wire that connects the blue (#5) lead from the UA150H to the blue (#5) lead on the control panel.

If the pump fails, this switch opens the compressor control circuit and stops water production before the reservoir overflows. The UA-150H will continue to ventilate or circulate air as normal, but will not dehumidify until this switch closes.

Electric Schematics of the UA-150H

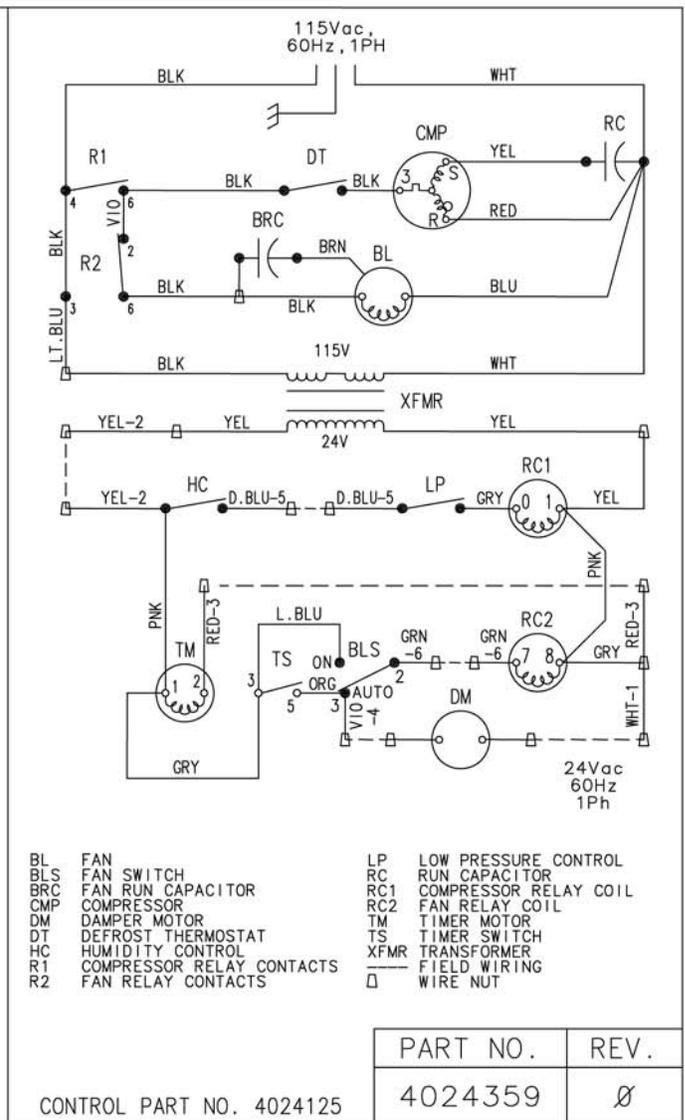
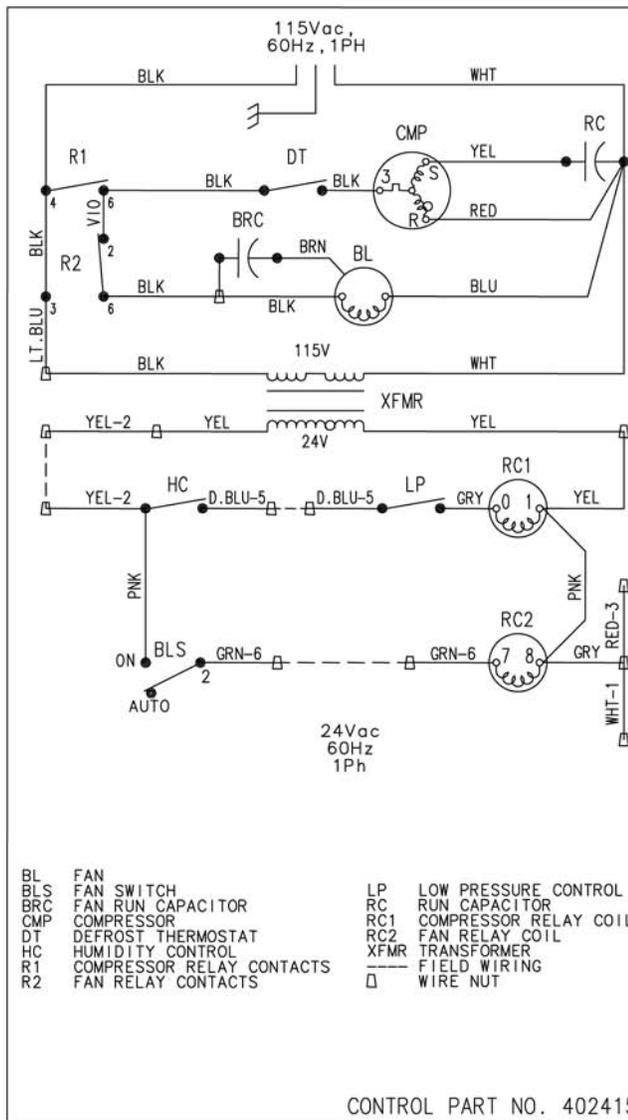

PART NO.	REV.
4024359	Ø

FOR HVAC INSTALLER ONLY

Pictorial Electrical Diagrams of UA-150H

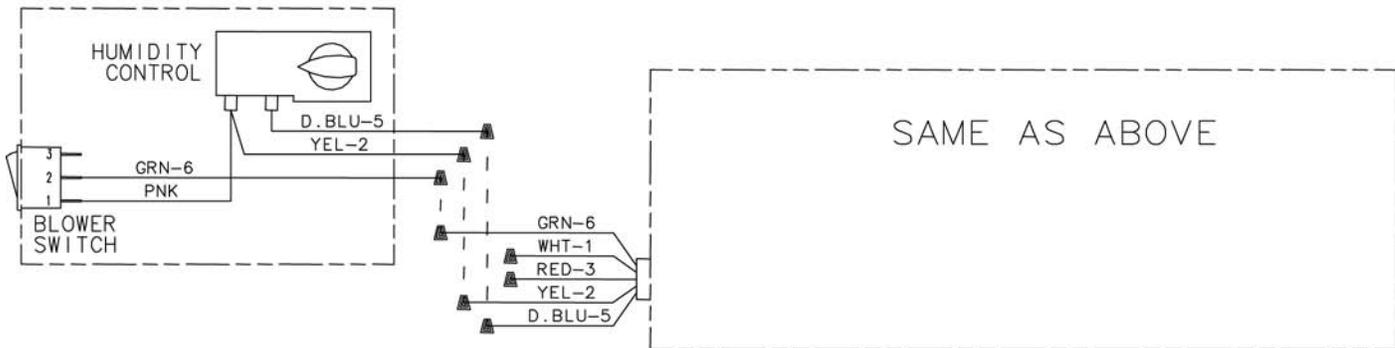
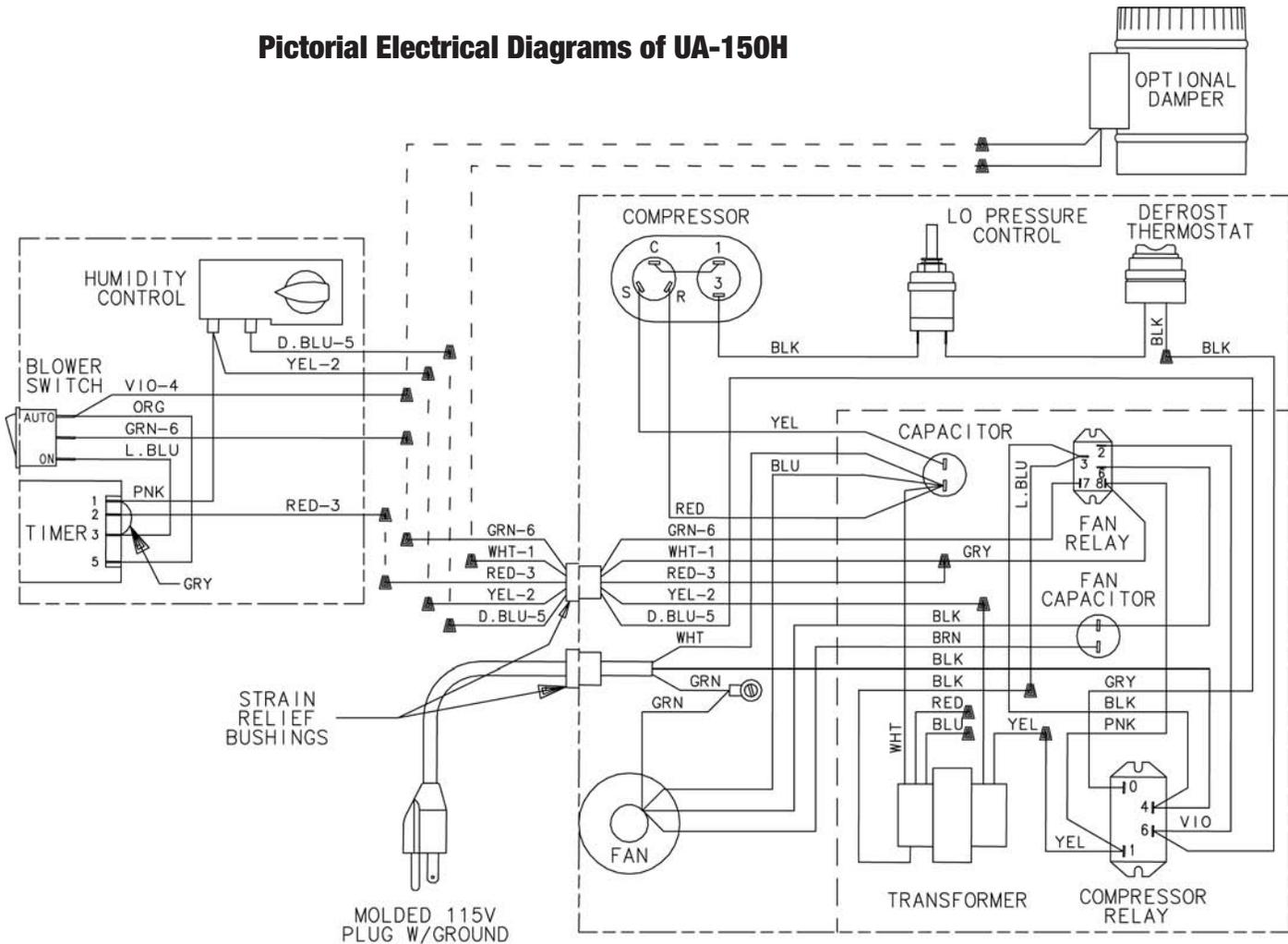

FOR HVAC INSTALLER ONLY

Wiring Diagrams

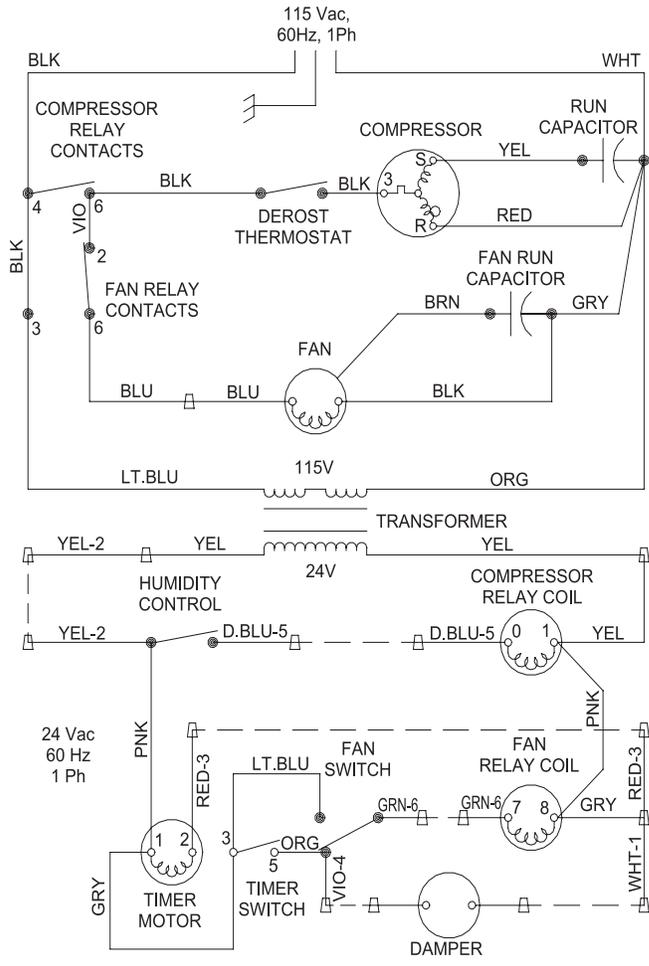
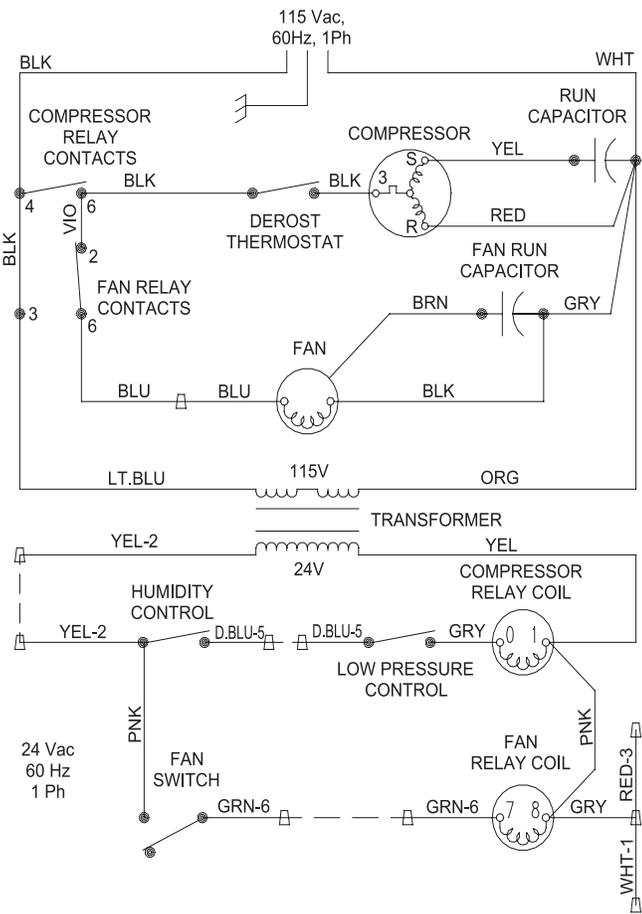

BE SURE JUMPER WIRE BETWEEN RC & RH IS IN PLACE

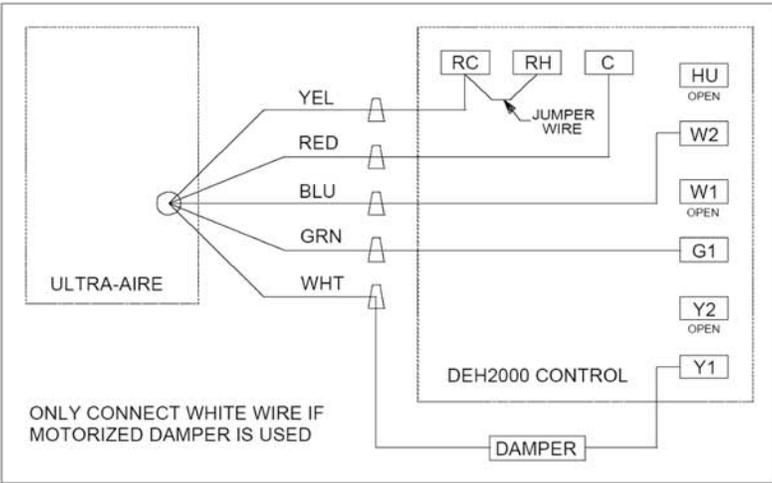

SERVICE PARTS LIST: UA-150H

ITEM	PART NO.	QTY.	DESCRIPTION
1	4024369	1	Air Filter, Pleated Cloth
2	4017777	2	Capillary Tube, .059" X .124" X 32.00" (not shown)
3	4023645	1	Compressor Service Kit, Carlyle (EBA120111A) (Includes Compressor, Capacitor & Overload)
4	4022595	1	Compressor Overload (EBA120111A) (not shown)
5	4022484	1	Compressor Relay, SPST, 24 Vac, 30A
6	4022740	1	Compressor Run Capacitor, 30 MFD
7	4022563	1	Condenser Coil
8	4021470	1	Defrost Thermostat,
	4021648	1	Defrost Thermostat Mounting Clip, (item 8) (not shown)
9	4022557	1	Evaporator Coil
10	4024270	1	Impeller Fan
11	4020924	1	Impeller Fan Relay, SPDT, 24 Vac, 15A
12	4024360	1	Impeller Fan Run Capacitor, 16MFD
13	4025087	1	Filter/Drier
14	4021626	1	Hose, Drain Pan, .56" ID x 8'
15	4024368	1	Inlet Collar, 10" Galvanized Steel
16	4023928	1	Inlet Collar, 6" Galvanized Steel with Damper
17	4022219	1	Low Pressure Control
18	4021332	1	Outlet Collar, 10" Galvanized Steel
19	4022487	1	Transformer, 120/24 Vac, 40 VA
20	4024359	1	Wiring Diagram (Not shown. See page 21)
21	40218181	1	Accumulator (not shown)
22	4024365	1	Cord/Wire Harness (not shown)
23	4024361	1	Wire Harness, Lo V (not shown)

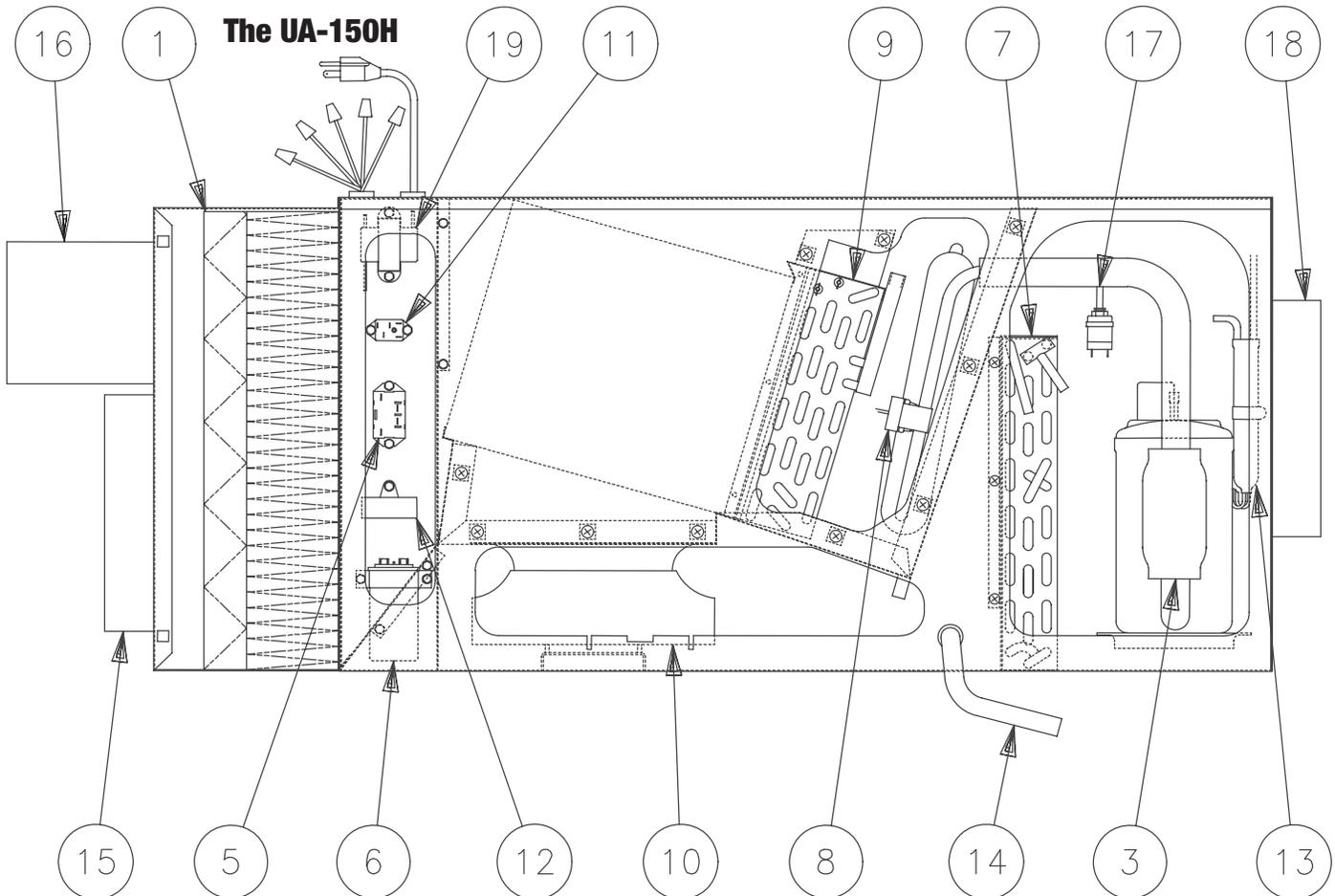

OPTIONAL PARTS LIST: UA-150H

ITEM	PART NO.	QTY.	DESCRIPTION
25	4024370	1	Air Filter, High Efficiency, Pleated Microglass Paper, 90%-95%
26	4024375	1	Check Damper, 10" Diameter (not shown)
27	4022220	1	Condensate Pump Kit, External
28	4024155	1	Control Panel Assembly, Humidity/Fan
29	4024125	1	Control Panel Assembly, Ventilation Timer & Humidity
30	4023660	1	Controller, Humidity
31	4023672	1	Duct Damper, 6" Diameter, Electrically Actuated (not shown)
32	4024153	1	Cover for Items 28 & 29 (not shown)
33	4021495	1	Knob, Black, .25" shaft
34	4024150	1	Instructions, Humidity/Fan (not shown)
35	4024122	1	Instructions, Ventilation Timer & Humidity (not shown)
36	4025560	1	Switch, Black, SPDT, On/Off
37	4022486	1	Timer, 7-Day, 24 Vac, Programmable
38	4024377	1	Optional External Insulation Kit (not shown)
39	4024431	1	Vibration Kit, 150H Series (not shown)

Accessories

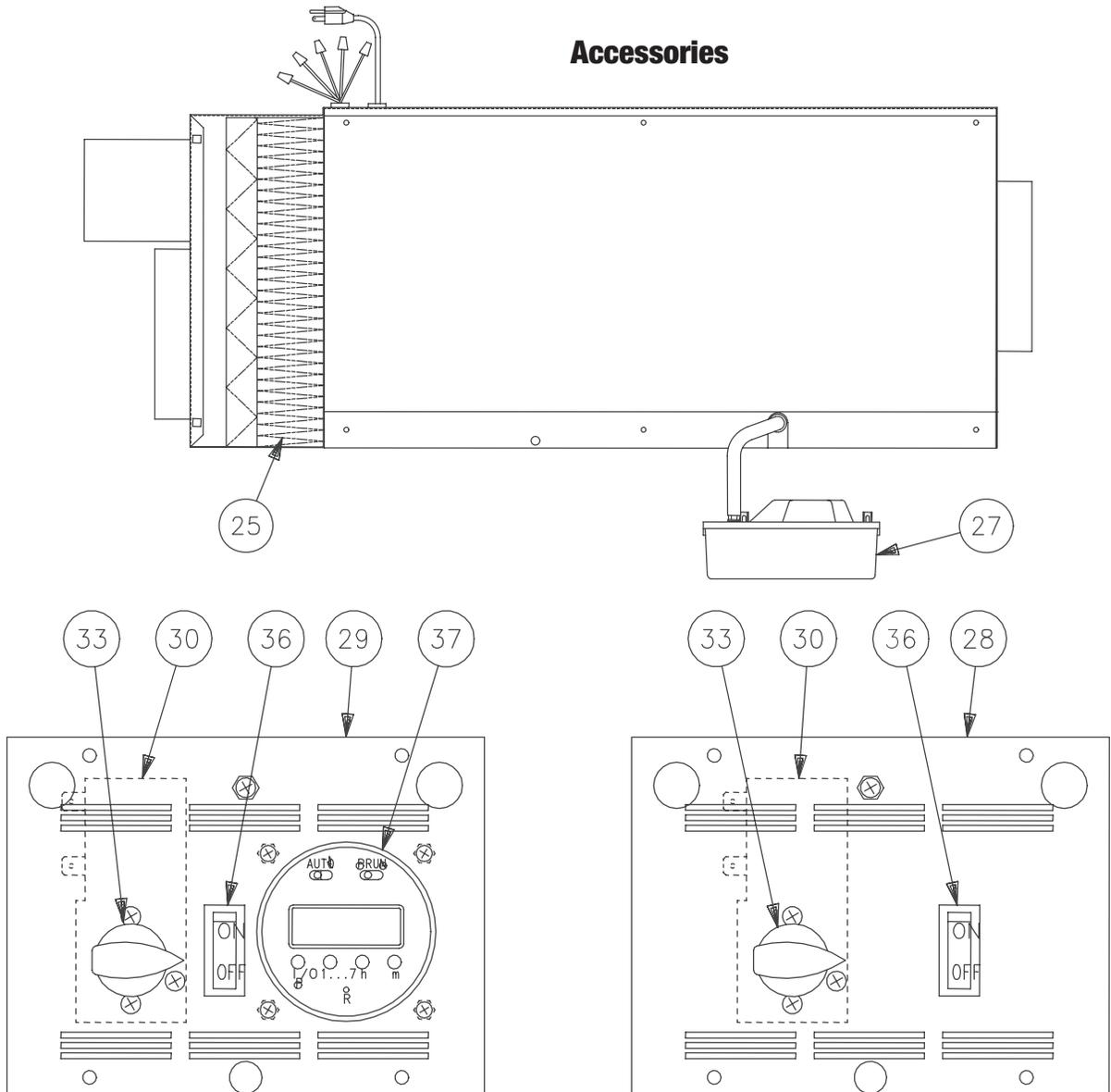

VIBRATION ISOLATION KIT: UA-150H

INSTRUCTIONS FOR ASSEMBLING THE VIBRATION ISOLATORS TO THE 150H

1. Lift one end of the UA-150H at least 12" off the floor.
2. Slide (2) of the nuts over each screw.
3. Attach the screws (with nuts) to the holes located in the bottom corners of the UA-150H.
4. Slide the grommet over the screw and nuts assembly.
5. Repeat for the other end of the UA-150H.

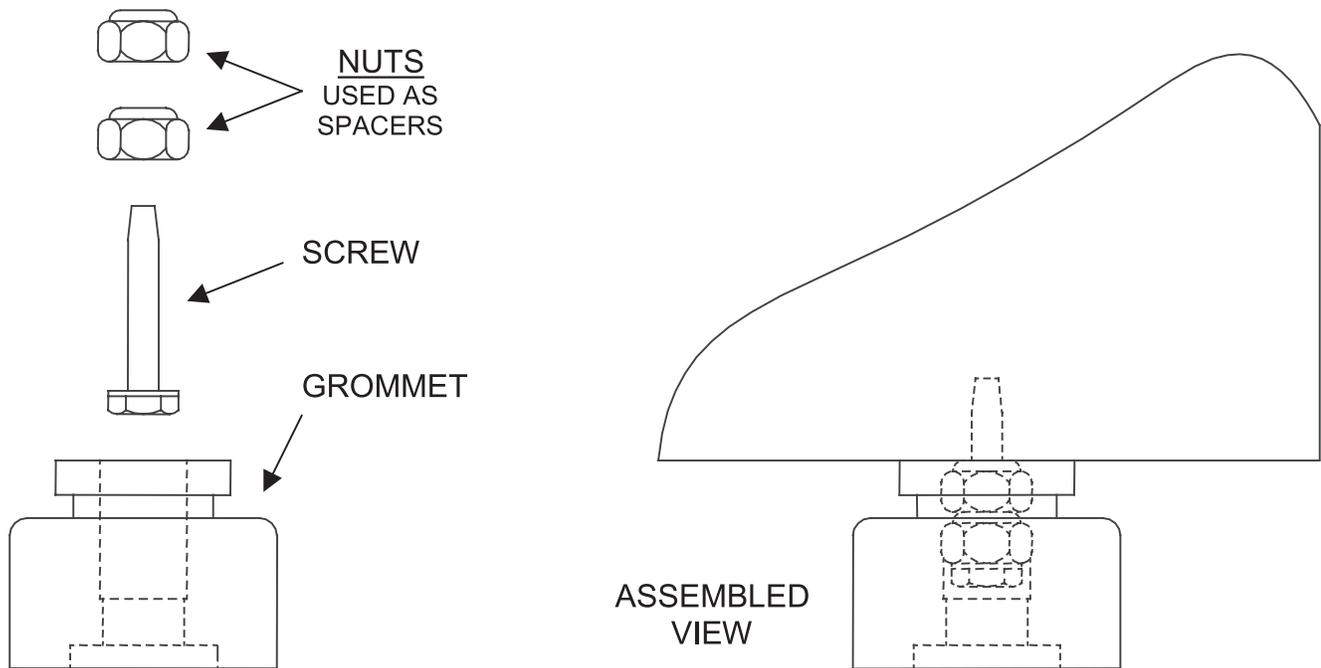

EXTERNAL INSULATION KIT: UA-150H

INSTRUCTIONS FOR APPLYING THE INSULATION TO THE UA-150H

The UA-150H must be clean, dry and at room temperature to apply the insulation kit. The insulation has a pressure sensitive adhesive with release paper applied to one side. To apply the insulation, remove the release paper and press the sheet firmly against the UA-150H. Apply insulation before installing the UA-150H if possible, as this is the easiest time to install the insulation kit.

Install the insulation kit as shown in the illustration below. After installing the insulation, cut out the holes for the supply and return connections and cut the seam around the removable front cover so it can be removed easily. If more insulation is needed two or more insulation kits may be applied to a single UA-150H.

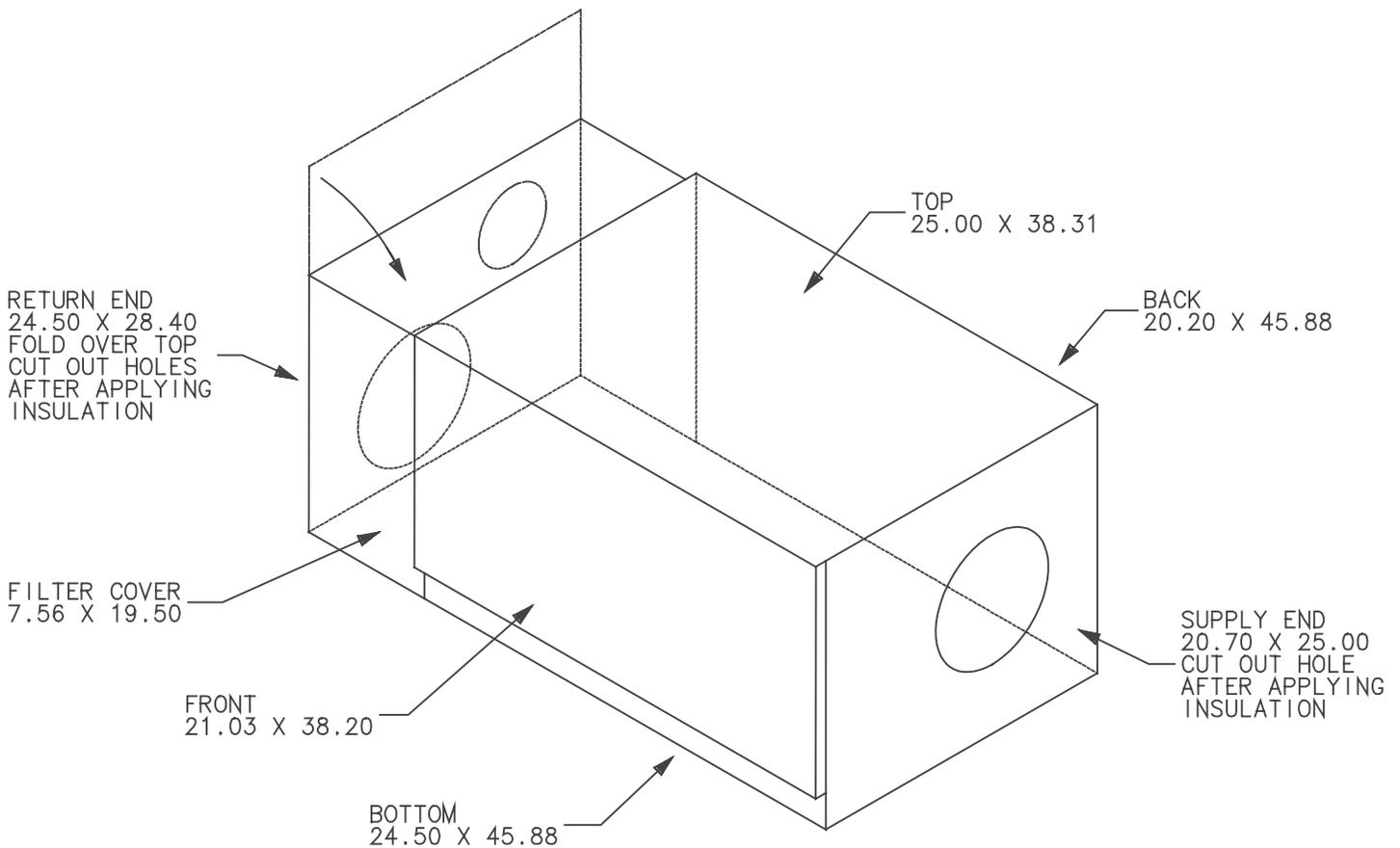

The dimensions below each location represent the size of the individual insulation pieces.

ATTENTION INSTALLER

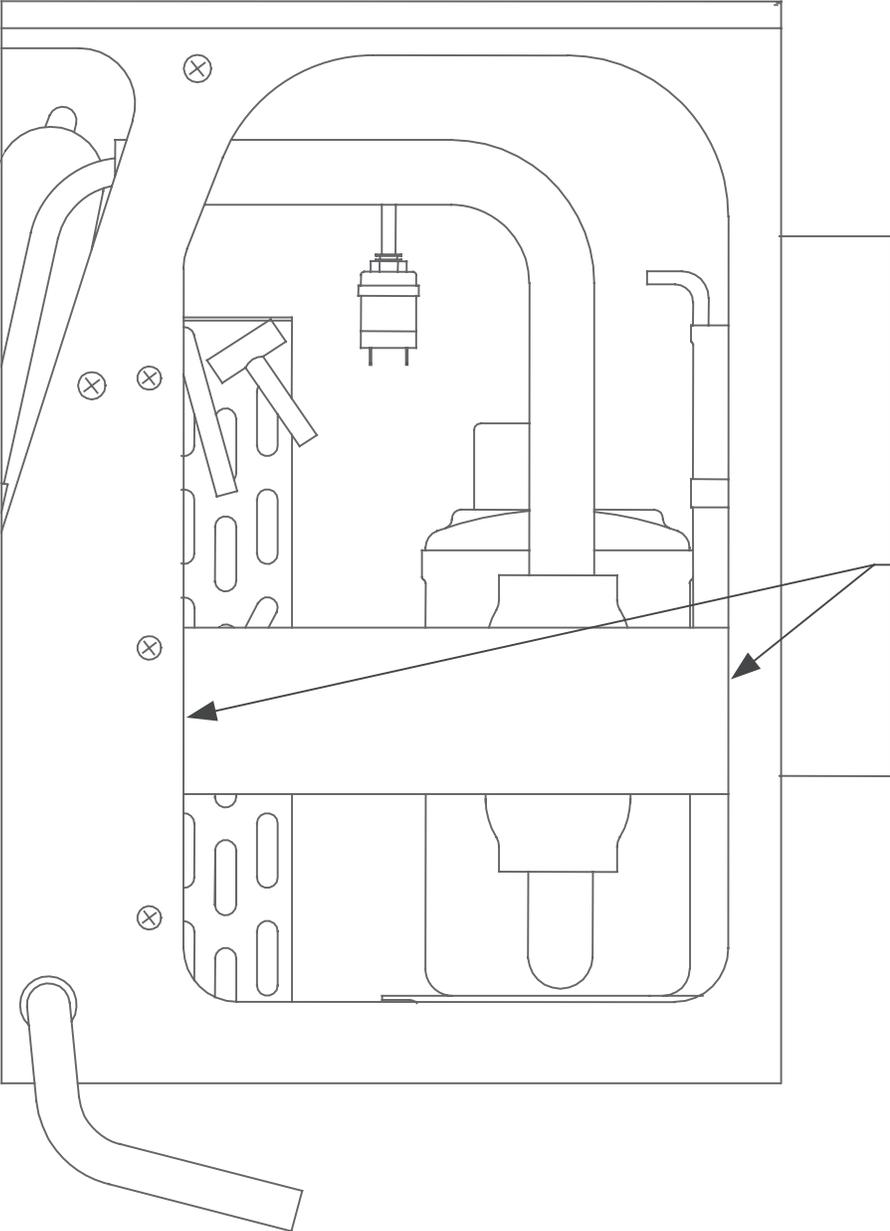

Remove cable tie and metal bracket (at serration's) after installation to prevent excessive noise and/or vibration.

ULTRA-AIRE 150H Dehumidifier Limited Warranty

WARRANTOR:

Therma-Stor LLC
PO Box 8680
Madison, WI 53708
Telephone: 1-800-533-7533

WHO IS COVERED: This warranty extends only to the original residential end-user of the Ultra-Aire 150H dehumidifier, and may not be assigned or transferred.

FIRST YEAR WARRANTY: Therma-Stor LLC warrants that, for one (1) year the Ultra-Aire 150H dehumidifier will operate free from any defects in materials and workmanship, or Therma-Stor LLC will, at its option, repair or replace the defective part(s), free of any charge.

SECOND THROUGH FIFTH YEAR WARRANTY: Therma-Stor LLC further warrants that for a period of five (5) years, the condenser, evaporator, and compressor of the Ultra-Aire 150H dehumidifier will operate free of any defects in material or workmanship, or Therma-Stor LLC, at its option, will repair or replace the defective part(s), provided that all labor and transportation charges for the part(s) shall be borne by the end-user.

END-USER RESPONSIBILITIES: Warranty service must be performed by a Servicer authorized by Therma-Stor LLC. If the end-user is unable to locate or obtain warranty service from an authorized Servicer, he should call Therma-Stor LLC at the above number and ask for the Therma-Stor LLC Service Department, which will then arrange for covered warranty service. Warranty service will be performed during normal working hours.

The End-user must present proof of purchase (lease) upon request, by use of the warranty card or other reasonable and reliable means. The end-user is responsible for normal care. This warranty only applies to residential applications and does not cover any defect, malfunction, etc. resulting

from misuse, abuse, lack of normal care, corrosion, freezing, tampering, modification, unauthorized or improper repair or installation, accident, acts of nature or any other cause beyond Therma-Stor LLC's reasonable control.

LIMITATIONS AND EXCLUSIONS: If any Ultra-Aire 150H Dehumidifier part is repaired or replaced, the new part shall be warranted for only the remainder of the original warranty period applicable thereto (but all warranty periods will be extended by the period of time, if any, that the Ultra-Aire 150H Dehumidifier is out of service while awaiting covered warranty service).

UPON THE EXPIRATION OF THE WRITTEN WARRANTY APPLICABLE TO THE ULTRA-AIRE DEHUMIDIFIER OR ANY PART THEREOF, ALL OTHER WARRANTIES IMPLIED BY LAW, INCLUDING MERCHANTABILITY AND FITNESS FOR A PARTICULAR PURPOSE, SHALL ALSO EXPIRE. ALL WARRANTIES MADE BY THERMA-STOR LLC ARE SET FORTH HEREIN, AND NO CLAIM MAY BE MADE AGAINST THERMA-STOR LLC BASED ON ANY ORAL WARRANTY. IN NO EVENT SHALL THERMA-STOR LLC, IN CONNECTION WITH THE SALE, INSTALLATION, USE, REPAIR OR REPLACEMENT OF ANY ULTRA-AIRE DEHUMIDIFIER OR PART THEREOF BE LIABLE UNDER ANY LEGAL THEORY FOR ANY SPECIAL, INDIRECT OR CONSEQUENTIAL DAMAGES INCLUDING WITHOUT LIMITATION WATER DAMAGE (THE END-USER SHOULD TAKE PRECAUTIONS AGAINST SAME), LOST PROFITS, DELAY, OR LOSS OF USE OR DAMAGE TO ANY REAL OR PERSONAL PROPERTY.

Some states do not allow limitations on how long an implied warranty lasts, and some do not allow the exclusion or limitation of incidental or consequential damages, so one or both of these limitation may not apply to you.

LEGAL RIGHTS: This warranty gives you specific legal rights, and you may also have other rights which vary from state to state.





Therma-Stor LLC

PO Box 8680 • Madison, WI 53708

Phone: 608-222-5301 • Fax: 608-222-1447

Web: www.thermastor.com • Email: sales@thermastor.com

Information in this document is subject to change without notice. No part of this document may be reproduced or transmitted in any form or by any means, electronic or mechanical, for any purpose, without the express written permission of Therma-Stor LLC. © 2006 Therma-Stor LLC. All rights reserved.
