



# Santa Fe<sup>TM</sup> Rx

A unique dehumidifier solution that can be integrated into the living space. The **Santa Fe Rx** is a great solution for a living room, bedroom, office space, or anywhere that needs supplemental dehumidification. Its clean design blends into any home or office décor.

<b>Part Number:</b>	4030440	
<b>Blower:</b>	230 CFM @ 0.0" WG	
<b>Power:</b>	630 watts @ 80°F and 60% RH	
<b>Supply Voltage:</b>	115 volt – 1phase – 60 Hz	
<b>Current Draw:</b>	5.4 amps	
<b>Operating Temp.:</b>	60°F Min., 95°F Max.	
<b>Sized for:</b>	2,200 Sq. Ft. - Typical	
<b>Minimum Performance at:</b>		
	<b>80°F and 60%RH</b>	<b>70°F and 60%RH</b>
<b>Water Removal:</b>	74 Pints/Day	66 Pints/Day
<b>Efficiency:</b>	5.2 Pints/kWh	5.03 Pints/kWh
<b>Energy Factor:</b>	2.47 L/kWh	2.38 L/kWh
<b>Air Filter:</b>	MERV-13, Standard Pleat	
<b>Size:</b>	16" x 20" x 2"	
<b>Power Cord:</b>	10', 115 VAC, Ground	
<b>Drain Hose:</b>	3/16" ID x 20', 15' Lift Capacity (Internal pump included)	
<b>Drain Hose:</b>	5/16" OD x 20', 15' Lift Capacity (Internal pump included)	
<b>Refrigerant Type:</b>	R410A (Refer to manufacturers label for more information)	
<b>Refrigerant Amount:</b>	1 lb., 8 oz.	

Dimensions:	Unit	With Secondary Filter Housing	Shipping
Width:	23"	23"	24"
Height:	37.5"	37.5"	46"
Length:	20"	24.75"	26"
Weight:	130 lbs		146 lbs

#### Optional Accessories:

4021475	MERV-11 Filter (16" x 20" x 2")
4027420	MERV-11 Filters 4-Pack
4027424	MERV-11 Filters 12-Pack
4037723	MERV-13 Filter (16" x 20" x 2")
4037733	MERV-13 Filters 4-Pack
4037734	MERV-13 Filters 12-Pack
4023869	Filter Housing
4022489	MERV-14 Filter (16" x 20" x 2") (needs filter housing, 4023869 - use 2)
4024145	HEPA Filter (needs filter housing)
4024528	Bulk Carbon Granules (5 gallon bucket)

- **Automatic condensate removal** via internal condensate pump
- Insulated cabinet and reduced fan speed ensure **quiet operation**
- Only 5.4 amps resulting in **low operating costs**
- **Large capacity** water removal of 74 pints/day
- **High efficiency** of 5.2 pints/kWh, far better than most conventional dehumidifiers
- MERV-13 Filter is standard and provides **superior air filtration**
- **Additional filtration options** include Carbon Granules and HEPA

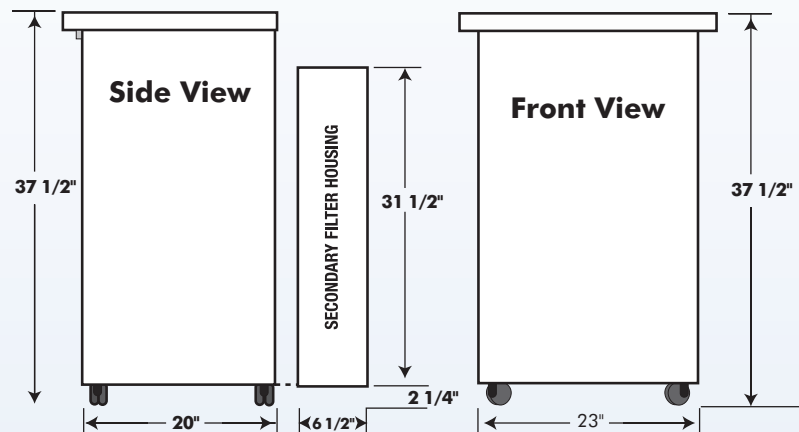
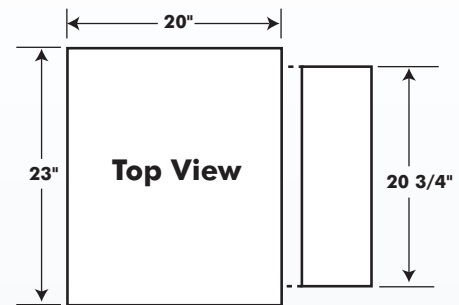

## Santa Fe Rx with Secondary Filter Housing

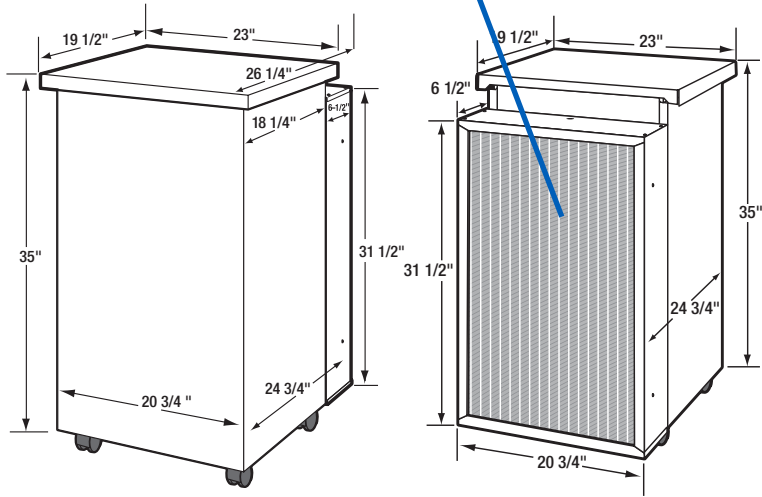

## Santa Fe Rx Control Panel

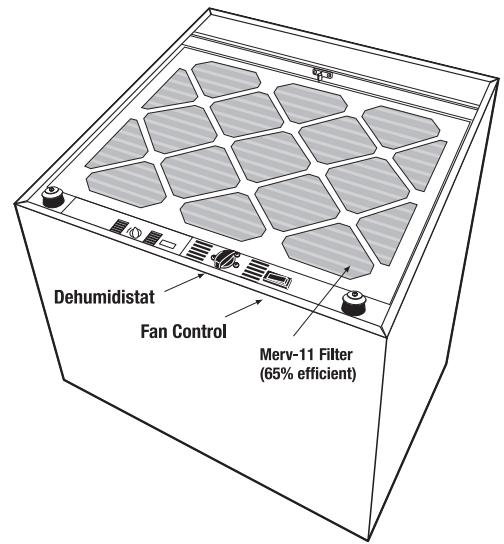

The Best in the Industry!

[www.Santa-Fe-Products.com](http://www.Santa-Fe-Products.com) ■ 1.800.533.7533

Rev 10/16/17